



Installation of the Water Main Replacement for Seminole Apartments

Solicitation No: FY19-IFB-01

Issue Date: April 11, 2019

Submission Deadline: Friday, May 3, 2019 @ 2:00 p.m.
(Prevailing Tampa Florida time)

Pre-Bid Conference: Thursday, April 18, 2019 @ 10:00 a.m.

Last Day for Questions: Thursday, April 25, 2019 @ 12:00 p.m.

TAMPA HOUSING AUTHORITY

Jerome Ryans, President / CEO

BOARD OF COMMISSIONERS

Susan Johnson-Velez, Chairperson **James A. Cloar, Vice-Chairperson**

Bemetra L. Simmons

Hazel S. Harvey

Billi Johnson-Griffin

Rubin E. Padgett

Tina D. Washington, Contracting Officer

5301 W. Cypress Street Tampa, Florida 33607

Phone: (813)341-9101, ext. 3500

Fax: (813)367-0760

AN EQUAL OPPORTUNITY EMPLOYER



TABLE OF CONTENTS

Bidding Information & Contractual Legal Documents

Seminole Park Apartments Water Main Replacement

I. BIDDING REQUIREMENTS	SECTION
<hr/>	
Table of Contents	00 01 10
Invitation to Bid	00 11 16
Instructions to Bidders for Contracts (HUD 5369)	00 21 13
Detailed Scope of Work	00 24 13
II. BID PACKAGE (Submit the Following to the Authority)	
<hr/>	
Bid Form.....	00 41 00
Bid Bond (Required if bid is over \$25,000.00).....	00 43 13
Representations, Certifications and Other Statement of Bidders (HUD 5369A).....	00 45 00
Statement of Bidder’s Qualifications.....	00 45 13
Non Collusive Affidavit.....	00 45 19
Section 3 and MBE Compliance Certification Forms (Including Contractor List).....	00 62 39
Sworn Statement Under Section 287.133(3)(A), Florida Statutes, On Public Entity Crimes	
III. BONDS AND CERTIFICATES (Submit the Following to the Authority upon Contract award)	
<hr/>	
Performance Bond.....	00 61 13.13
Payment Bond.....	00 61 13.16
IV. CONTRACTING REQUIREMENTS	
<hr/>	
General Conditions for Construction Contracts (HUD 5370).....	00 72 13
Special Conditions.....	00 73 00
V. WAGE DETERMINATION	
<hr/>	
Davis Bacon Wage Decisions (Building)	00 73 43



This Page Intentionally Left Blank.



INVITATION FOR BID

Bid No. FY19-IFB-01

Date Issued: April 11, 2019

The Housing Authority of the City of Tampa (the "Authority") will receive sealed bids for **the Installation of the Water Main Replacement for Seminole Apartments located at 4706 Muskogee Ct. Tampa, FL 33610** until **2:00 p.m. (prevailing Tampa, Florida time)** on **Friday, May 3, 2019**. All bids are to be submitted to the attention of the 1st floor front desk of the Authority's Contracting offices located at 5301 West Cypress Street, Tampa, Florida, 33607, **at which time and place all bids will be publicly opened and read aloud**. Bids received after the above stated time will not be considered.

Qualified Contractors may pick up copies of the bidding documents by visiting THA's website at <http://www.thafl.com/Departments/Contract-n-Procurement/Default.aspx> or by submitting an email request to biddersquestions@thafl.com.

The Authority will hold a pre-bid conference on **Thursday, April 18, 2019 at 10:00 a.m.** at the Contracting Office located on the third floor of 5301 West Cypress Street, Tampa, Florida 33607. A site visit will follow immediately after the pre-bid conference.

A Bid Guarantee in the amount of 5% of the total base bid must accompany each bid that exceeds \$25,000. Bid guarantee shall be a Bid Bond secured by a surety company authorized to do business in the State of Florida and listed in the latest Department of Treasury Circular 570 published in the Federal Register; or as permitted by state law, a certified check, bank draft, or U.S. Government Bond at per value. If bid security is not submitted the Authority will reject the bid. All Bid Guarantees must be made payable to the Housing Authority of the City Tampa. Personal checks will not be accepted. In addition, a Non-Collusive Affidavit must be supplied with each bid that exceeds \$25,000.

For all contracts that exceed \$100,000, the successful bidder will be required to furnish and pay for the satisfactory Performance and Payment bonding in the amount of 100% of the contract price. The successful bidder will be required to furnish certificates of insurance in accordance with the General Conditions.

The Contractor must ensure that employees and applicants for employment are not discriminated against because of race, color, creed, gender, disability, or national origin. The successful bidder will be required to present a certification of Affidavit Action Compliance.

In accordance with Department of Housing and Urban Development (HUD) regulations, the Authority is required to establish a goal of awarding at least 30 percent of the dollar value of construction contracts to Minority Business Enterprises (MBEs) or General Contractors with

MBE participation. In accordance therewith, prime contractors are required to meet or exceed this 30% MBE participation goal by time of bid.

In accordance with Section 3 of the U. S. Department of Housing and Urban Development Act of 1968, the Authority requires all construction Contractors, to the greatest extent feasible, to provide training, contracting and employment opportunities to low income residents residing in the Authority's public housing communities.

The Authority intends to award a contract on the basis of the lowest and most responsible TOTAL base bid and in a single Contract for all work to be performed in the above referenced project.

No bid shall be withdrawn for a period of sixty (60) days subsequent to the opening of without the prior written consent of the Authority.

Bidders shall carefully examine the documents and construction site to obtain first-hand knowledge of existing conditions. Contractors will not be given an extra payment for conditions that can be determined by examining the site and documents.

The Authority reserves the right to waive irregularities and to reject any or all bids. Failure to submit a bid properly may result in rejection of the Bid.

Documents to be submitted with Bid

- Complete Bid Form, Section 00410.
- Complete Bid Bond (for bids over \$25,000), Section 00430.
- Complete Representation, Certifications and Other Statements of Bidders (HUD 5369A) Section 00450.
- Complete Statement of Bidder's Qualifications, Section 00460.
- Complete Section 3 & MBE Compliance Certification Form Section 00470.
- Complete Non-Collusive Affidavit, Section 00480.
- Sworn Statement Under Section 287.133(3)(A), Florida Statutes, On Public Entity Crimes

THE HOUSING AUTHORITY OF THE CITY OF TAMPA IS AN EQUAL OPPORTUNITY EMPLOYER, BY ORDER OF JEROME D. RYANS, PRESIDENT/CEO.

END OF INVITATION FOR BID





Instructions to Bidders for Contracts Public and Indian Housing Programs

Table of Contents

Clause	Page
1. Bid Preparation and Submission	1
2. Explanations and Interpretations to Prospective Bidders	1
3. Amendments to Invitations for Bids	1
4. Responsibility of Prospective Contractor	1
5. Late Submissions, Modifications, and Withdrawal of Bids	1
6. Bid Opening	2
7. Service of Protest	2
8. Contract Award	2
9. Bid Guarantee	2
10. Assurance of Completion	3
11. Preconstruction Conference	3
12. Indian Preference Requirements	3

1. Bid Preparation and Submission

(a) Bidders are expected to examine the specifications, drawings, all instructions, and, if applicable, the construction site (see also the contract clause entitled **Site Investigation and Conditions Affecting the Work** of the General Conditions of the Contract for Construction). Failure to do so will be at the bidders' risk.

(b) All bids must be submitted on the forms provided by the Public Housing Agency/Indian Housing Authority (PHA/IHA). Bidders shall furnish all the information required by the solicitation. Bids must be signed and the bidder's name typed or printed on the bid sheet and each continuation sheet which requires the entry of information by the bidder. Erasures or other changes must be initialed by the person signing the bid. Bids signed by an agent shall be accompanied by evidence of that agent's authority. (Bidders should retain a copy of their bid for their records.)

(c) Bidders must submit as part of their bid a completed form HUD-5369-A, "Representations, Certifications, and Other Statements of Bidders."

(d) All bid documents shall be sealed in an envelope which shall be clearly marked with the words "Bid Documents," the Invitation for Bids (IFB) number, any project or other identifying number, the bidder's name, and the date and time for receipt of bids.

(e) If this solicitation requires bidding on all items, failure to do so will disqualify the bid. If bidding on all items is not required, bidders should insert the words "No Bid" in the space provided for any item on which no price is submitted.

(f) Unless expressly authorized elsewhere in this solicitation, alternate bids will not be considered.

(g) Unless expressly authorized elsewhere in this solicitation, bids submitted by telegraph or facsimile (fax) machines will not be considered.

(h) If the proposed contract is for a Mutual Help project (as described in 24 CFR Part 905, Subpart E) that involves Mutual Help contributions of work, material, or equipment, supplemental information regarding the bid advertisement is provided as an attachment to this solicitation.

2. Explanations and Interpretations to Prospective Bidders

(a) Any prospective bidder desiring an explanation or interpretation of the solicitation, specifications, drawings, etc., must request it at

least 7 days before the scheduled time for bid opening. Requests may be oral or written. Oral requests must be confirmed in writing. The only oral clarifications that will be provided will be those clearly related to solicitation procedures, i.e., not substantive technical information. No other oral explanation or interpretation will be provided. Any information given a prospective bidder concerning this solicitation will be furnished promptly to all other prospective bidders as a written amendment to the solicitation, if that information is necessary in submitting bids, or if the lack of it would be prejudicial to other prospective bidders.

(b) Any information obtained by, or provided to, a bidder other than by formal amendment to the solicitation shall not constitute a change to the solicitation.

3. Amendments to Invitations for Bids

(a) If this solicitation is amended, then all terms and conditions which are not modified remain unchanged.

(b) Bidders shall acknowledge receipt of any amendment to this Solicitation

(1) by signing and returning the amendment,

(2) by identifying the amendment number and date on the bid form, or (3) by letter, telegram, or facsimile, if those methods are authorized in the solicitation. The PHA/IHA must receive acknowledgement by the time and at the place specified for receipt of bids. Bids which fail to acknowledge the bidder's receipt of any amendment will result in the rejection of the bid if the amendment(s) contained information which substantively changed the PHA's/IHA's requirements.

(c) Amendments will be on file in the offices of the PHA/IHA and the Architect at least 7 days before bid opening.

4. Responsibility of Prospective Contractor

(a) The PHA/IHA will award contracts only to responsible prospective Contractors who have the ability to perform successfully under the terms and conditions of the proposed contract. In determining the responsibility of a bidder, the PHA/IHA will consider such matters as the bidder's:

- (1) Integrity;
- (2) Compliance with public policy;
- (3) Record of past performance; and
- (4) Financial and technical resources (including construction and technical equipment).

(b) Before a bid is considered for award, the bidder may be requested by the PHA/IHA to submit a statement or other documentation regarding any of the items in paragraph (a) above. Failure by the bidder to provide such additional information shall render the bidder non-responsible and ineligible for award.

5. Late Submissions, Modifications, and Withdrawal of Bids

(a) Any bid received at the place designated in the solicitation after the exact time specified for receipt will not be considered unless it is received before award is made and it:

(1) Was sent by registered or certified mail not later than the fifth calendar day before the date specified for receipt of offers (e.g.) an offer submitted in response to a solicitation requiring receipt of offers by the 20th of the month must have been mailed by the 15th.

(2) Was sent by mail, or if authorized by the solicitation, was sent by telegram or via facsimile, and it is determined by the PHA/IHA that the late



receipt was due solely to mishandling by the PHA/IHA after receipt at the PHA/IHA; or

- (3) Was sent by U.S. Postal Service Express Mail Next Day Service - Post Office to Addressee, not later than 5:00 p.m. at the place of mailing two working days prior to the date specified for receipt of proposals. The term "working days" excludes weekends and observed holidays.

(b) Any modification or withdrawal of a bid is subject to the same conditions as in paragraph (a) of this provision.

(c) The only acceptable evidence to establish the date of mailing of a late bid, modification, or withdrawal sent either by registered or certified mail is the U.S. or Canadian Postal Service postmark both on the envelope or wrapper and on the original receipt from the U.S. or Canadian Postal Service. Both postmarks must show a legible date or the bid, modification, or withdrawal shall be processed as if mailed late. "Postmark" means a printed, stamped, or otherwise placed impression (exclusive of a postage meter machine impression) that is readily identifiable without further action as having been supplied and affixed by employees of the U.S. or Canadian Postal Service on the date of mailing. Therefore, bidders should request the postal clerk to place a hand cancellation bull's-eye postmark on both the receipt and the envelope or wrapper.

(d) The only acceptable evidence to establish the time of receipt at the PHA/IHA is the time/date stamp of PHA/IHA on the proposal wrapper or other documentary evidence of receipt maintained by the PHA/IHA.

(e) The only acceptable evidence to establish the date of mailing of a late bid, modification, or withdrawal sent by Express Mail Next Day Service-Post Office to Addressee is the date entered by the post office receiving clerk on the "Express Mail Next Day Service-Post Office to Addressee" label and the postmark on both the envelope or wrapper and on the original receipt from the U.S. Postal Service. "Postmark" has the same meaning as defined in paragraph (c) of this provision, excluding postmarks of the Canadian Postal Service. Therefore, bidders should request the postal clerk to place a legible hand cancellation bull's eye postmark on both the receipt and Failure by a bidder to acknowledge receipt of the envelope or wrapper.

(f) Notwithstanding paragraph (a) of this provision, a late modification of an otherwise successful bid that makes its terms more favorable to the PHA/IHA will be considered at any time it is received and may be accepted.

(g) Bids may be withdrawn by written notice, or if authorized by this solicitation, by telegram (including mailgram) or facsimile machine transmission received at any time before the exact time set for opening of bids; provided that written confirmation of telegraphic or facsimile withdrawals over the signature of the bidder is mailed and postmarked prior to the specified bid opening time. A bid may be withdrawn in person by a bidder or its authorized representative if, before the exact time set for opening of bids, the identity of the person requesting withdrawal is established and the person signs a receipt for the bid.

6. Bid Opening

All bids received by the date and time of receipt specified in the solicitation will be publicly opened and read. The time and place of opening will be as specified in the solicitation. Bidders and other interested persons may be present.

7. Service of Protest

(a) Definitions. As used in this provision: "Interested party" means an actual or prospective bidder whose direct economic interest would be affected by the award of the contract.

"Protest" means a written objection by an interested party to this solicitation or to a proposed or actual award of a contract pursuant to this solicitation.

(b) Protests shall be served on the Contracting Officer by obtaining written and dated acknowledgement from Contracting Officer at designate the official or location where a protest may be served on:

Ms. Tina Washington, Contracting Officer
THA Purchasing & Contracting Office
5301 West Cypress Street
Tampa, Florida 33607

(c) All protests shall be resolved in accordance with the PHA's/IHA's protest policy and procedures, copies of which are maintained at the PHA/IHA.

8. Contract Award

(a) The PHA/IHA will evaluate bids in response to this solicitation without discussions and will award a contract to the responsible bidder whose bid, conforming to the solicitation, will be most advantageous to the PHA/IHA considering only price and any price-related factors specified in the solicitation.

(b) If the apparent low bid received in response to this solicitation exceeds the PHA's/IHA's available funding for the proposed contract work, the PHA/IHA may either accept separately priced items (see 8(e) below) or use the following procedure to determine contract award. The PHA/IHA shall apply in turn to each bid (proceeding in order from the apparent low bid to the high bid) each of the separately priced bid deductible items, if any, in their priority order set forth in this solicitation. If upon the application of the first deductible item to all initial bids, a new low bid is within the PHA's/IHA's available funding, then award shall be made to that bidder. If no bid is within the available funding amount, then the PHA/IHA shall apply the second deductible item. The PHA/IHA shall continue this process until an evaluated low bid, if any, is within the PHA's/IHA's available funding. If upon the application of all deductibles, no bid is within the PHA's/IHA's available funding, or if the solicitation does not request separately priced deductibles, the PHA/IHA shall follow its written policy and procedures in making any award under this solicitation.

(c) In the case of tie low bids, award shall be made in accordance with the PHA's/IHA's written policy and procedures.

(d) The PHA/IHA may reject any and all bids, accept other than the lowest bid (e.g., the apparent low bid is unreasonably low), and waive informalities or minor irregularities in bids received, in accordance with the PHA's/IHA's written policy and procedures.

(e) Unless precluded elsewhere in the solicitation, the PHA/IHA may accept any item or combination of items bid.

(f) The PHA/IHA may reject any bid as nonresponsive if it is materially unbalanced as to the prices for the various items of work to be performed. A bid is materially unbalanced when it is based on prices significantly less than cost for some work and prices which are significantly overstated for other work.

(g) A written award shall be furnished to the successful bidder within the period for acceptance specified in the bid and shall result in a binding contract without further action by either party.

9. Bid Guarantee (applicable to construction and equipment



contracts exceeding \$25,000)

All bids must be accompanied by a negotiable bid guarantee which shall not be less than five percent (5%) of the amount of the bid. The bid guarantee may be a certified check, bank draft, U.S. Government

Bonds at par value or a bid bond secured by a surety company acceptable to the U.S. Government and authorized to do business in the state where the work is to be performed. In the case where the work under the contract will be performed on an Indian reservation area, the bid guarantee may also be an irrevocable Letter of Credit (see provision 10, Assurance of Completion, below). Certified checks and bank drafts must be made payable to the order of the PHA/IHA. The bid guarantee shall insure the execution of the contract and the furnishing of a method of assurance of completion by the successful bidder as required by the solicitation. Failure to submit a bid guarantee with the bid shall result in the rejection of the bid. Bid guarantees submitted by unsuccessful bidders will be returned as soon as practicable after bid opening.

10. Assurance of Completion

(a) Unless otherwise provided in State law, the successful bidder shall furnish an assurance of completion prior to the execution of any contract under this solicitation. This assurance may be [Contracting Officer check applicable items] —

(1) a performance and payment bond in a penal sum of 100 percent of the contract price; or, as may be required or permitted by State law;

(2) separate performance and payment bonds, each for 50 percent or more of the contract price;

(3) a 20 percent cash escrow;

(4) a 25 percent irrevocable letter of credit; or,

(5) an irrevocable letter of credit for 10 percent of the total contract price with a monitoring and disbursements agreement with the IHA (applicable only to contracts awarded by an IHA under the Indian Housing Program).

(b) Bonds must be obtained from guarantee or surety companies acceptable to the U.S. Government and authorized to do business in the state where the work is to be performed. Individual sureties will not be considered. U.S. Treasury Circular Number 570, published annually in the Federal Register, lists companies approved to act as sureties on bonds securing Government contracts, the maximum underwriting limits on each contract bonded, and the States in which the company is licensed to do business. Use of companies listed in this circular is mandatory. Copies of the circular may be downloaded on the U.S. Department of Treasury website <http://www.fms.treas.gov/c570/index.html>, or ordered for a minimum fee by contacting the Government Printing Office at (202) 512-2168.

(c) Each bond shall clearly state the rate of premium and the total amount of premium charged. The current power of attorney for the person who signs for the surety company must be attached to the bond. The effective date of the power of attorney shall not precede the date of the bond. The effective date of the bond shall be on or after the execution date of the contract.

(d) Failure by the successful bidder to obtain the required assurance of completion within the time specified, or within such extended period as the PHA/IHA may grant based upon reasons determined adequate by the PHA/IHA, shall render the bidder ineligible for award. The PHA/IHA may then either award the contract to the next

lowest responsible bidder or solicit new bids. The PHA/IHA may retain the ineligible bidder's bid guarantee.

11. Preconstruction Conference (applicable to construction contracts)

After award of a contract under this solicitation and prior to the start of work, the successful bidder will be required to attend a preconstruction conference with representatives of the PHA/IHA and its architect/engineer, and other interested parties convened by the PHA/IHA. The conference will serve to acquaint the participants with the general plan of the construction operation and all other requirements of the contract (e.g., Equal Employment Opportunity, Labor Standards). The PHA/IHA will provide the successful bidder with the date, time, and place of the conference.

12. Indian Preference Requirements (applicable only if this solicitation is for a contract to be performed on a project for an Indian Housing Authority)

(a) HUD has determined that the contract awarded under this solicitation is subject to the requirements of section 7(b) of the Indian Self-Determination and Education Assistance Act (25 U.S.C. 450e(b)). Section 7(b) requires that any contract or subcontract entered into for the benefit of Indians shall require that, to the greatest extent feasible

(1) Preferences and opportunities for training and employment (other than core crew positions; see paragraph (h) below) in connection with the administration of such contracts or subcontracts be given to qualified "Indians." The Act defines "Indians" to mean persons who are members of an Indian tribe and defines "Indian tribe" to mean any Indian tribe, band, nation, or other organized group or community, including any Alaska Native village or regional or village corporation as defined in or established pursuant to the Alaska Native Claims Settlement Act, which is recognized as eligible for the special programs and services provided by the United States to Indians because of their status as Indians; and,

(2) Preference in the award of contracts or subcontracts in connection with the administration of contracts be given to Indian organizations and to Indian-owned economic enterprises, as defined in section 3 of the Indian Financing Act of 1974 (25 U.S.C. 1452). That Act defines "economic enterprise" to mean any Indian owned commercial, industrial, or business activity established or organized for the purpose of profit, except that the Indian ownership must constitute not less than 51 percent of the enterprise; "Indian organization" to mean the governing body of any Indian tribe or entity established or recognized by such governing body; "Indian" to mean any person who is a member of any tribe, band, group, pueblo, or community which is recognized by the Federal Government as eligible for services from the Bureau of Indian Affairs and any "Native" as defined in the Alaska Native Claims Settlement Act; and Indian "tribe" to mean any Indian tribe, band, group, pueblo, or community including Native villages and Native groups (including corporations organized by Kenai, Juneau, Sitka, and Kodiak) as defined in the Alaska Native Claims Settlement Act, which is recognized by the Federal Government as eligible for services from the Bureau of Indian Affairs.

(b) (1) The successful Contractor under this solicitation shall comply with the requirements of this provision in awarding all subcontracts under the contract and in providing training and employment opportunities.

(2) A finding by the IHA that the contractor, either (i) awarded a subcontract without using the procedure required by the IHA, (ii) falsely represented that subcontracts would be awarded to



Indian enterprises or organizations; or, (iii) failed to comply with the contractor's employment and training preference bid statement shall be grounds for termination of the contract or for the assessment of penalties or other remedies.

(c) If specified elsewhere in this solicitation, the IHA may restrict the solicitation to qualified Indian-owned enterprises and Indian organizations. If two or more (or a greater number as specified elsewhere in the solicitation) qualified Indian-owned enterprises or organizations submit responsive bids, award shall be made to the qualified enterprise or organization with the lowest responsive bid. If fewer than the minimum required number of qualified Indian-owned enterprises or organizations submit responsive bids, the IHA shall reject all bids and readvertise the solicitation in accordance with paragraph (d) below.

(d) If the IHA prefers not to restrict the solicitation as described in paragraph (c) above, or if after having restricted a solicitation an insufficient number of qualified Indian enterprises or organizations submit bids, the IHA may advertise for bids from non-Indian as well as Indian-owned enterprises and Indian organizations. Award shall be made to the qualified Indian enterprise or organization with the lowest responsive bid if that bid is –

(1) Within the maximum HUD-approved budget amount established for the specific project or activity for which bids are being solicited; and

(2) No more than the percentage specified in 24 CFR 905.175(c) higher than the total bid price of the lowest responsive bid from any qualified bidder. If no responsive bid by a qualified Indian-owned economic enterprise or organization is within the stated range of the total bid price of the lowest responsive bid from any qualified enterprise, award shall be made to the bidder with the lowest bid.

(e) Bidders seeking to qualify for preference in contracting or subcontracting shall submit proof of Indian ownership with their bids. Proof of Indian ownership shall include but not be limited to:

(1) Certification by a tribe or other evidence that the bidder is an Indian. The IHA shall accept the certification of a tribe that an individual is a member.

(2) Evidence such as stock ownership, structure, management, control, financing and salary or profit sharing arrangements of the enterprise.

(f) (1) All bidders must submit with their bids a statement describing how they will provide Indian preference in the award of subcontracts. The specific requirements of that statement and the factors to be used by the IHA in determining the statement's adequacy are included as an attachment to this solicitation. Any bid that fails to include the required statement shall be rejected as nonresponsive. The IHA may require that comparable statements be provided by subcontractors to the successful Contractor, and may require the Contractor to reject any bid or proposal by a subcontractor that fails to include the statement.

(2) Bidders and prospective subcontractors shall submit a certification (supported by credible evidence) to the IHA in any instance where the bidder or subcontractor believes it is infeasible to provide Indian preference in subcontracting. The acceptance or rejection by the IHA of the certification shall be final. Rejection shall disqualify the bid from further consideration.

(g) All bidders must submit with their bids a statement detailing their employment and training opportunities and their plans to provide preference to Indians in implementing the contract; and the number or percentage of Indians anticipated to be employed and trained.

Comparable statements from all proposed subcontractors must be submitted. The criteria to be used by the IHA in determining the statement(s)'s adequacy are included as an attachment to this solicitation. Any bid that fails to include the required statement(s), or that includes a statement that does not meet minimum standards required by the IHA shall be rejected as nonresponsive.

(h) Core crew employees. A core crew employee is an individual who is a bona fide employee of the contractor at the time the bid is submitted; or an individual who was not employed by the bidder at the time the bid was submitted, but who is regularly employed by the bidder in a supervisory or other key skilled position when work is available. Bidders shall submit with their bids a list of all core crew employees.

(i) Preference in contracting, subcontracting, employment, and training shall apply not only on-site, on the reservation, or within the IHA's jurisdiction, but also to contracts with firms that operate outside these areas (e.g., employment in modular or manufactured housing construction facilities).

(j) Bidders should contact the IHA to determine if any additional local preference requirements are applicable to this solicitation.

(k) The IHA does does not [Contracting Officer check applicable box] maintain lists of Indian-owned economic enterprises and Indian organizations by specialty (e.g., plumbing, electrical, foundations), which are available to bidders to assist them in meeting their responsibility to provide preference in connection with the administration of contracts and subcontracts.

END OF HUD FORM 5369

DETAILED SCOPE OF WORK

Seminole Park Apartments Water Main Replacement

The project entails the installation of a replacement water main which serves the Seminole Park Apartments. The installation of four inch water main, two inch service laterals, along with all necessary valves, meter setters and appurtenances will replace the aging infrastructure which currently serves the apartment complex. The existing water line shall remain in operation until the new system is placed into operation.

Work includes, but is not limited to, the installation of all required sediment control measures; tree protection measures; demolition and restoration of sidewalk, pavement, landscaping, and turf; trenching, bedding, and installation of both PVC and HDPE piping; disconnection of all building services, meters, and appurtenances; and testing and disinfection of the distribution system. The site contractor shall locate all existing utilities prior to any excavation at their own expense.

The Tampa Housing Authority reserves the right to increase funds during the contract term if work exceeds original estimates, subject to required authorizations. Beyond the initial one-year term, the Tampa Housing Authority reserves the right to renew the contract for up to two (2) years.

The Contractor shall provide 2 [Fixed/Portable] project signs to be located at the direction of the Tampa Housing Authority.

PLCTED: 2-28-2018 10:48 PM BT.T.m

SITE DATA

MAILING ADDRESS
5301 W CYPRESS ST, STE 100
TAMPA, FL 33607-1734
FOLIO NUMBER: 039508-0000
SITE AREA: 6.36-ACRES
ZONING: PD 98-0437
PROPOSED USE: 7503 NON-PROFIT APTS.

CONSTRUCTION PLANS FOR

SEMINOLE PARK APARTMENTS WATER MAIN REPLACEMENT

4706 MUSKOGEE CT. TAMPA, FL. 33610

LEGAL DESCRIPTION

THE W 650 FT OF THE S 1/2 OF NE 1/4 OF NE 1/4 LESS
R/W...

THE FOLLOWING DESCRIBED PROPERTY COM 619.47
FT W OF SE COR OF NE 1/4 FOR POB THN W 74 FT THN
N 605 MOL TO SLY R/W OF POCAHONTAS AVE THN E 74
FT THN S TO SLY R/W OF DIANA ST TO POB

LYING IN A PORTION OF
SECTION 33, TOWNSHIP 28 SOUTH, RANGE 19 EAST
HILLSBOROUGH COUNTY, FLORIDA

SHEET INDEX

- C01 - COVER SHEET
- C02- PARTIAL AS-BUILT AND TOPOGRAPHIC SURVEY
- C03- EXISTING CONDITIONS AND DEMOLITION PLAN
- C04 - EROSION CONTROL AND SWPPP NOTES
- C05- UTILITY PLAN
- C06 - DETAILS
- C07 - DETAILS

GENERAL INFORMATION



OWNER:
TAMPA HOUSING AUTHORITY
5301 W CYPRESS ST,
TAMPA FL 33607



CIVIL ENGINEER:
CRIBB PHILBECK WEAVER GROUP
3918 N HIGHLAND AVE
TAMPA, FLORIDA 33603
(813) 361-2644
CERTIFICATION OF
AUTHORIZATION: 26618
ENGINEER OF RECORD
MICHAEL STALZER, PE 79953



SURVEYOR:
CRIBB PHILBECK WEAVER GROUP
3918 N HIGHLAND AVE
TAMPA, FLORIDA 33603
(813) 361-2644
JEFFREY M. SCHWARTZ,
PROFESSIONAL SURVEYOR &
MAPPER LICENSE
NUMBER: LS6618
PROFESSIONAL SURVEYOR
& MAPPER BUSINESS LICENSE
NUMBER: LB8232

UTILITY INFORMATION

WATER AND SEWER:
CITY OF TAMPA
306 EAST JACKSON STREET
TAMPA, FLORIDA 33602

ELECTRIC:
TELCO
TAMPA ELECTRIC COMPANY
P.O. BOX 31318
TAMPA, FLORIDA 33631-3318

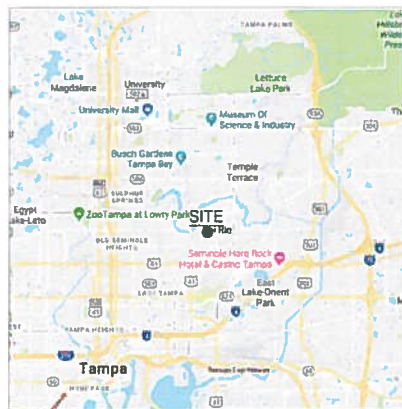

VICINITY MAP
N.T.S.

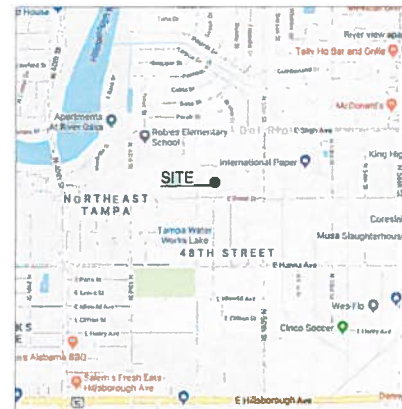

LOCATION MAP
N.T.S.

NO	DATE	REVISION

MICHAEL E. STALZER, P.E.
FL. LIC. NO. 79953

ENGINEER OF RECORD
MICHAEL STALZER, PE
NO. 79953
CIVIL
3918 N HIGHLAND AVE.
TAMPA, FLORIDA 33603
(813) 361-2644
CERTIFICATION OF
AUTHORIZATION: 26618



SEMINOLE PARK APARTMENTS
WATER MAIN REPLACEMENT
TAMPA, FLORIDA
TAMPA HOUSING AUTHORITY

JOB NO.: 180143
DRAWN BY: TAM
DESIGNED BY: TAM
CHECKED BY: JEK
DATE: 02/27/19

COVER

SHEET NO.
C01
C01 OF 7

S:\ATL-F-PROJECT-F-180143-Tampa Housing Seminoles Park Apts\ADD-DWG-Layouts\180143-C01.dwg

PRINTED: 2/26/2019 11:17:49 AM B1-T14

S:\Projects\2019\1801143\Tampa Housing Authority\2019\Topographic\5 - Topo.dwg

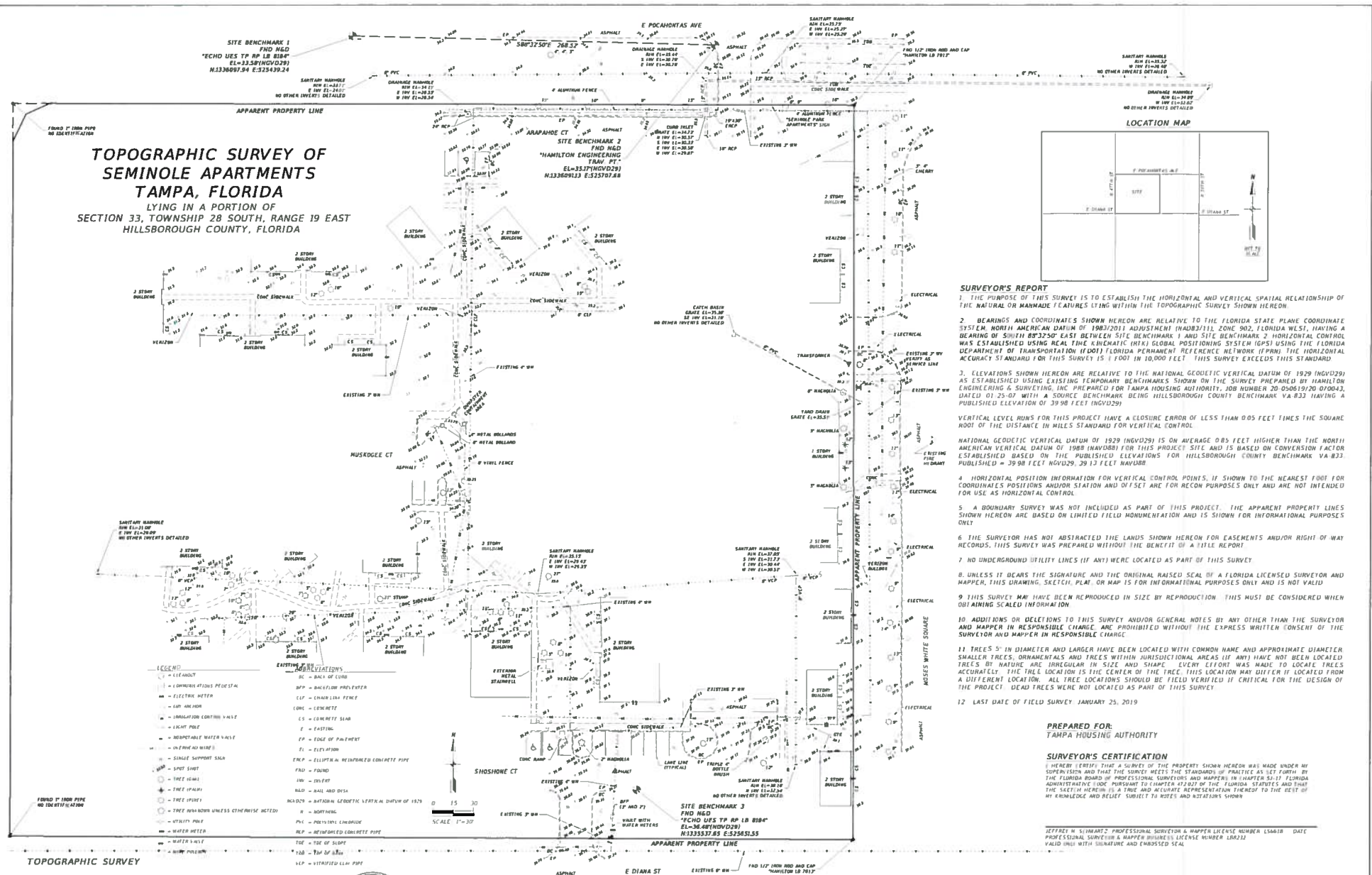

TOPOGRAPHIC SURVEY OF SEMINOLE APARTMENTS
 LYING IN A PORTION OF SECTION 33, TOWNSHIP 28 SOUTH, RANGE 19 EAST HILLSBOROUGH COUNTY, FLORIDA



- SURVEYOR'S REPORT**
1. THE PURPOSE OF THIS SURVEY IS TO ESTABLISH THE HORIZONTAL AND VERTICAL SPATIAL RELATIONSHIP OF THE NATURAL OR MANMADE FEATURES LYING WITHIN THE TOPOGRAPHIC SURVEY SHOWN HEREON.
 2. BEARINGS AND COORDINATES SHOWN HEREON ARE RELATIVE TO THE FLORIDA STATE PLANE COORDINATE SYSTEM, NORTH AMERICAN DATUM OF 1983/2011 ADJUSTMENT (NAD83/11), ZONE 902, FLORIDA WEST, HAVING A BEARING OF SOUTH 88°32'50" EAST BETWEEN SITE BENCHMARK 1 AND SITE BENCHMARK 2. HORIZONTAL CONTROL WAS ESTABLISHED USING REAL TIME KINEMATIC (RTK) GLOBAL POSITIONING SYSTEM (GPS) USING THE FLORIDA DEPARTMENT OF TRANSPORTATION (FDOT) FLORIDA PERMANENT REFERENCE NETWORK (FPRN). THE HORIZONTAL ACCURACY STANDARD FOR THIS SURVEY IS 1 FOOT IN 10,000 FEET. THIS SURVEY EXCEEDS THIS STANDARD.
 3. ELEVATIONS SHOWN HEREON ARE RELATIVE TO THE NATIONAL GEODETIC VERTICAL DATUM OF 1929 (NGVD29) AS ESTABLISHED USING EXISTING TEMPORARY BENCHMARKS SHOWN ON THE SURVEY PREPARED BY HAMILTON ENGINEERING & SURVEYING, INC. PREPARED FOR TAMPA HOUSING AUTHORITY, JOB NUMBER 20-050019-00 (0004), DATED 01-25-07 WITH A SOURCE BENCHMARK BEING HILLSBOROUGH COUNTY BENCHMARK VA-833 HAVING A PUBLISHED ELEVATION OF 39.98 FEET (NGVD29).
 - VERTICAL LEVEL RUNS FOR THIS PROJECT HAVE A CLOSURE ERROR OF LESS THAN 0.05 FEET TIMES THE SQUARE ROOT OF THE DISTANCE IN FEET STANDARD FOR VERTICAL CONTROL.
 - NATIONAL GEODETIC VERTICAL DATUM OF 1929 (NGVD29) IS ON AVERAGE 0.83 FEET HIGHER THAN THE NORTH AMERICAN VERTICAL DATUM OF 1988 (NAVDS88) FOR THIS PROJECT. SITE AND IS BASED ON CONVERSION FACTOR ESTABLISHED BASED ON THE PUBLISHED ELEVATIONS FOR HILLSBOROUGH COUNTY BENCHMARK VA-833, PUBLISHED = 39.98 FEET (NGVD29), 39.13 FEET (NAVDS88).
 4. HORIZONTAL POSITION INFORMATION FOR VERTICAL CONTROL POINTS, IF SHOWN TO THE NEAREST FOOT FOR COORDINATES POSITIONS AND/OR STATION AND OFFSET ARE FOR RECON PURPOSES ONLY AND NOT INTENDED FOR USE AS HORIZONTAL CONTROL.
 5. A BOUNDARY SURVEY WAS NOT INCLUDED AS PART OF THIS PROJECT. THE APPARENT PROPERTY LINES SHOWN HEREON ARE BASED ON LIMITED FIELD DOCUMENTATION AND IS SHOWN FOR INFORMATIONAL PURPOSES ONLY.
 6. THE SURVEYOR HAS NOT ABSTRACTED THE LANDS SHOWN HEREON FOR EASEMENTS AND/OR RIGHT OF WAY RECORDS. THIS SURVEY WAS PREPARED WITHOUT THE BENEFIT OF A TITLE REPORT.
 7. NO UNDERGROUND UTILITY LINES (IF ANY) WERE LOCATED AS PART OF THIS SURVEY.
 8. UNLESS IT BEARS THE SIGNATURE AND THE ORIGINAL RAISED SEAL OF A FLORIDA LICENSED SURVEYOR AND MAPPER, THIS DRAWING, SKETCH, PLAN, OR MAP IS FOR INFORMATIONAL PURPOSES ONLY AND IS NOT VALID.
 9. THIS SURVEY MAY HAVE BEEN REPRODUCED IN SIZE OR REPRODUCTION. THIS MUST BE CONSIDERED WHEN OBTAINING SCALED INFORMATION.
 10. ADDITIONS OR DELETIONS TO THIS SURVEY AND/OR GENERAL NOTES BY ANY OTHER THAN THE SURVEYOR AND MAPPER IN RESPONSIBLE CHARGE ARE PROHIBITED WITHOUT THE EXPRESS WRITTEN CONSENT OF THE SURVEYOR AND MAPPER IN RESPONSIBLE CHARGE.
 11. TREES 5" IN DIAMETER AND LARGER HAVE BEEN LOCATED WITH COMMON NAME AND APPROXIMATE DIAMETER. SMALLER TREES, ORNAMENTALS AND TREES WITHIN JURISDICTIONAL AREAS (IF ANY) HAVE NOT BEEN LOCATED. TREES OF NATURE ARE IRREGULAR IN SIZE AND SHAPE. EVERY EFFORT WAS MADE TO LOCATE TREES ACCURATELY. THE TREE LOCATION IS THE CENTER OF THE TREE. THIS LOCATION MAY VARY IF LOCATED FROM A DIFFERENT LOCATION. ALL TREE LOCATIONS SHOULD BE FIELD VERIFIED IF CRITICAL FOR THE DESIGN OF THE PROJECT. DEAD TREES WERE NOT LOCATED AS PART OF THIS SURVEY.
 12. LAST DATE OF FIELD SURVEY: JANUARY 25, 2019

PREPARED FOR:
 TAMPA HOUSING AUTHORITY

SURVEYOR'S CERTIFICATION
 I HEREBY CERTIFY THAT A SURVEY OF THE PROPERTY SHOWN HEREON WAS MADE UNDER MY SUPERVISION AND THAT THE SURVEY MEETS THE STANDARDS OF PRACTICE AS SET FORTH BY THE FLORIDA BOARD OF PROFESSIONAL SURVEYORS AND MAPPERS IN CHAPTER 5517, FLORIDA ADMINISTRATIVE CODE PURSUANT TO CHAPTER 408 OF THE FLORIDA STATUTES AND THAT THE SHEET HEREON IS A TRUE AND ACCURATE REPRESENTATION THEREOF TO THE BEST OF MY KNOWLEDGE AND BELIEF. SUBJECT TO NOTES AND NOTATIONS SHOWN.

JEFFREY M. SHAWART, PROFESSIONAL SURVEYOR & MAPPER LICENSE NUMBER 156618 DATE 02/27/19
 PROFESSIONAL SURVEYOR & MAPPER LICENSE NUMBER 1801143
 VALID UNLESS WITH SIGNATURE AND ENDORSED SEAL

NO.	DATE	REVISION



JEFFREY M. SHAWART, PROFESSIONAL SURVEYOR & MAPPER LICENSE NUMBER 156618 DATE 02/27/19
 PROFESSIONAL SURVEYOR & MAPPER LICENSE NUMBER 1801143
 VALID UNLESS WITH SIGNATURE AND ENDORSED SEAL



SEMINOLE PARK APARTMENTS
 WATER MAIN REPLACEMENT
 TAMPA, FLORIDA
 TAMPA HOUSING AUTHORITY

JOB NO. 1801143
 DRAWN BY J. SCHWARTZ
 DESIGNED BY D. HEATH
 CHECKED BY JEA
 DATE 02/27/19

PARTIAL AS-BUILT AND TOPOGRAPHIC SURVEY - SV1

SHEET NO. C02
 C02 OF 7

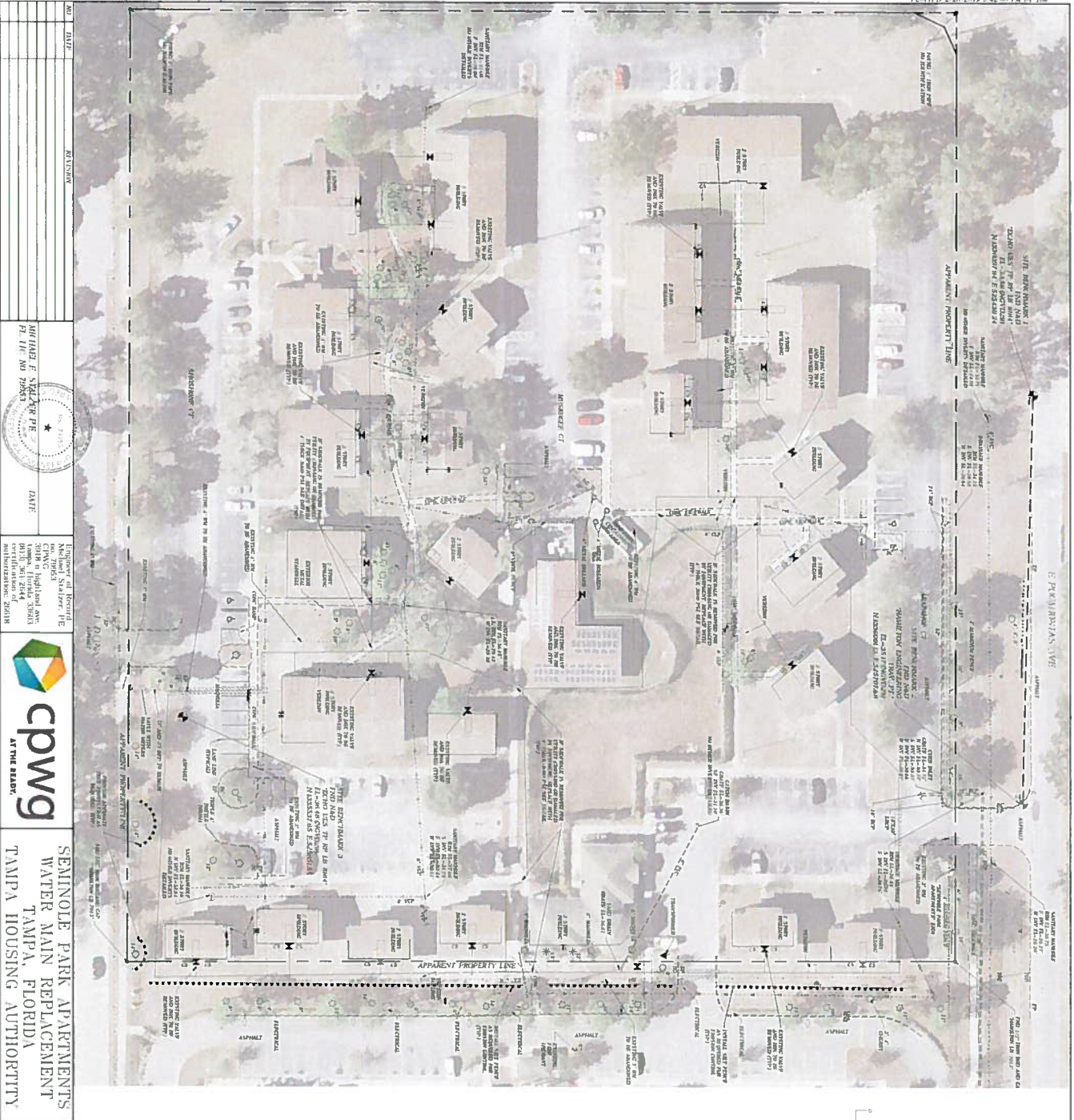

NO.	DATE	BY	DESCRIPTION
1	02/27/19	JES	ISS
2			
3			
4			
5			
6			
7			
8			
9			
10			

SEMINOLE PARK APARTMENTS
 WATER MAIN REPLACEMENT
 TAMPA, FLORIDA
 TAMPA HOUSING AUTHORITY

DATE: 02/27/19

DESIGNED BY: TAD

DRAWN BY: JES

CHECKED BY: JES

DATE: 02/27/19

SHEET NO: C03

OF 7

EXISTING CONDITIONS AND DEMOLITION PLAN

DATE: 02/27/19

DESIGNED BY: TAD

DRAWN BY: JES

CHECKED BY: JES

DATE: 02/27/19

SHEET NO: C03

OF 7

DATE: 02/27/19

DESIGNED BY: TAD

DRAWN BY: JES

CHECKED BY: JES

DATE: 02/27/19

SHEET NO: C03

OF 7

DATE: 02/27/19

DESIGNED BY: TAD

DRAWN BY: JES

CHECKED BY: JES

DATE: 02/27/19

SHEET NO: C03

OF 7

DATE: 02/27/19

DESIGNED BY: TAD

DRAWN BY: JES

CHECKED BY: JES

DATE: 02/27/19

SHEET NO: C03

OF 7

DATE: 02/27/19

CONSTRUCTION AND LANDSCAPING RESTORATION NOTES

1. The contractor shall be responsible for verifying and adjusting all material quantities.
2. The contractor is responsible for compliance with all applicable building codes, ordinances and local regulations. The contractor shall be responsible for obtaining all necessary permits to perform the work.
3. The contractor shall be responsible for obtaining all necessary permits to perform the work, including but not limited to, excavation and foundation permits.
4. Prior to the start of construction, the contractor shall be responsible for furnishing themselves with the location of all existing underground utilities. The contractor shall be responsible for marking and protecting all existing underground utilities. The contractor shall be responsible for their own safety and the safety of others on the site.
5. The contractor shall be responsible for providing all construction safety and maintaining all safety, debris, stumps, concrete, and other debris.

PROTECTIVE BARRIERS REQUIREMENTS AND SPECIFICATIONS FOR EXISTING TREES TO REMAIN

PROTECTIVE BARRIERS are used during land acquisition and construction activities to protect trees and natural areas to be retained on a site.

PROTECTIVE BARRIERS must be installed around trees to be retained on a site. The contractor shall be responsible for installing and maintaining protective barriers around trees to be retained on a site. The contractor shall be responsible for their own safety and the safety of others on the site.

PROTECTIVE BARRIERS shall be installed around trees to be retained on a site. The contractor shall be responsible for installing and maintaining protective barriers around trees to be retained on a site. The contractor shall be responsible for their own safety and the safety of others on the site.

PROTECTIVE BARRIERS shall be installed around trees to be retained on a site. The contractor shall be responsible for installing and maintaining protective barriers around trees to be retained on a site. The contractor shall be responsible for their own safety and the safety of others on the site.

PROTECTIVE BARRIERS shall be installed around trees to be retained on a site. The contractor shall be responsible for installing and maintaining protective barriers around trees to be retained on a site. The contractor shall be responsible for their own safety and the safety of others on the site.

PROTECTIVE BARRIERS shall be installed around trees to be retained on a site. The contractor shall be responsible for installing and maintaining protective barriers around trees to be retained on a site. The contractor shall be responsible for their own safety and the safety of others on the site.

PROTECTIVE BARRIERS shall be installed around trees to be retained on a site. The contractor shall be responsible for installing and maintaining protective barriers around trees to be retained on a site. The contractor shall be responsible for their own safety and the safety of others on the site.

PROTECTIVE BARRIERS shall be installed around trees to be retained on a site. The contractor shall be responsible for installing and maintaining protective barriers around trees to be retained on a site. The contractor shall be responsible for their own safety and the safety of others on the site.

PROTECTIVE BARRIERS shall be installed around trees to be retained on a site. The contractor shall be responsible for installing and maintaining protective barriers around trees to be retained on a site. The contractor shall be responsible for their own safety and the safety of others on the site.

PROTECTIVE BARRIERS shall be installed around trees to be retained on a site. The contractor shall be responsible for installing and maintaining protective barriers around trees to be retained on a site. The contractor shall be responsible for their own safety and the safety of others on the site.

PROTECTIVE BARRIERS shall be installed around trees to be retained on a site. The contractor shall be responsible for installing and maintaining protective barriers around trees to be retained on a site. The contractor shall be responsible for their own safety and the safety of others on the site.

PROTECTIVE BARRIERS shall be installed around trees to be retained on a site. The contractor shall be responsible for installing and maintaining protective barriers around trees to be retained on a site. The contractor shall be responsible for their own safety and the safety of others on the site.

NO.	DATE	REVISION

MICHAEL E. SKIDMORE ARCHITECTS, P.A. 110 S. ALLE ST. SUITE 200 TAMPA, FLORIDA 33602 TEL: 813-251-4444 FAX: 813-251-4445 WWW.MSKA.COM	REGISTERED PROFESSIONAL ENGINEER NO. 35952 DATE:	REGISTERED PROFESSIONAL ENGINEER NO. 79453 DATE:
---	--	--

SEMINOLE PARK APARTMENTS WATER MAIN REPLACEMENT TAMPA, FLORIDA TAMPA HOUSING AUTHORITY	SHEET NO C01
---	-----------------

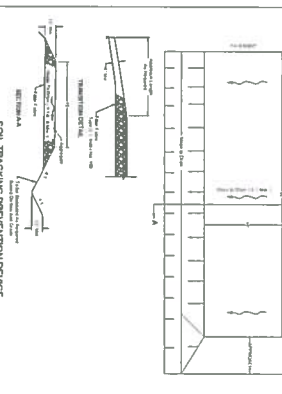
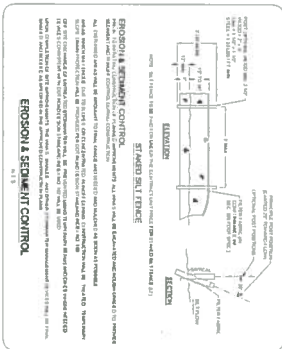

GENERAL EROSION CONTROL NOTES:

- 1. APPROXIMATE EROSION CONTROL MEASURES SHALL BE INSTALLED PRIOR TO THE START OF CONSTRUCTION ACTIVITIES (GREATER THAN 5 ACRES).
- 2. A COPY OF THE NOTICE OF INTENT FROM THE DEPARTMENT OF ENVIRONMENTAL PROTECTION (DPR) REGARDING EROSION CONTROL SHALL BE POSTED AT THE CONSTRUCTION SITE IN A PROMINENT PLACE FOR PUBLIC VIEWING.
- 3. THE EROSION CONTROL MEASURES SHALL BE MAINTAINED THROUGHOUT THE CONSTRUCTION PERIOD AND SHALL BE REMOVED OR MODIFIED AS NECESSARY.
- 4. THE EROSION CONTROL MEASURES SHALL BE MAINTAINED THROUGHOUT THE CONSTRUCTION PERIOD AND SHALL BE REMOVED OR MODIFIED AS NECESSARY.
- 5. PRESERVE EXISTING VEGETATION WHERE ATTAINABLE AND STABILIZE DISTURBED PORTIONS OF THE SITE TO PREVENT EROSION. EXISTING TREES SHALL BE MAINTAINED AND PROTECTED. EXISTING TREES SHALL BE MAINTAINED AND PROTECTED. EXISTING TREES SHALL BE MAINTAINED AND PROTECTED.
- 6. EROSION CONTROL MEASURES SHALL BE MAINTAINED THROUGHOUT THE CONSTRUCTION PERIOD AND SHALL BE REMOVED OR MODIFIED AS NECESSARY.
- 7. CONSTRUCTION SHALL ADHERE TO THE STATE OF FLORIDA DEPARTMENT OF ENVIRONMENTAL PROTECTION'S (DPR) EROSION CONTROL MEASURES.
- 8. CONSTRUCTION SHALL ADHERE TO THE STATE OF FLORIDA DEPARTMENT OF ENVIRONMENTAL PROTECTION'S (DPR) EROSION CONTROL MEASURES.
- 9. CONSTRUCTION SHALL ADHERE TO THE STATE OF FLORIDA DEPARTMENT OF ENVIRONMENTAL PROTECTION'S (DPR) EROSION CONTROL MEASURES.
- 10. CONSTRUCTION SHALL ADHERE TO THE STATE OF FLORIDA DEPARTMENT OF ENVIRONMENTAL PROTECTION'S (DPR) EROSION CONTROL MEASURES.
- 11. CONSTRUCTION SHALL ADHERE TO THE STATE OF FLORIDA DEPARTMENT OF ENVIRONMENTAL PROTECTION'S (DPR) EROSION CONTROL MEASURES.
- 12. CONSTRUCTION SHALL ADHERE TO THE STATE OF FLORIDA DEPARTMENT OF ENVIRONMENTAL PROTECTION'S (DPR) EROSION CONTROL MEASURES.
- 13. A PERMITTEE SHALL SUBMIT A COPY OF THE FOLLOWING TO THE FLORIDA DEPARTMENT OF ENVIRONMENTAL PROTECTION (DPR) PRIOR TO THE START OF CONSTRUCTION:
- 14. PERMITTEE SHALL SUBMIT A COPY OF THE FOLLOWING TO THE FLORIDA DEPARTMENT OF ENVIRONMENTAL PROTECTION (DPR) PRIOR TO THE START OF CONSTRUCTION:
- 15. PERMITTEE SHALL SUBMIT A COPY OF THE FOLLOWING TO THE FLORIDA DEPARTMENT OF ENVIRONMENTAL PROTECTION (DPR) PRIOR TO THE START OF CONSTRUCTION:

INTERSECTED SEQUENCE OF CONSTRUCTION ACTIVITIES AND EROSION CONTROL IMPLEMENTATION:

- 1. PROTECT EXISTING VEGETATION AND EROSION CONTROL MEASURES.
- 2. MAINTAIN EXISTING VEGETATION AND EROSION CONTROL MEASURES.
- 3. CONSTRUCT EROSION CONTROL MEASURES AND MAINTAIN THROUGHOUT CONSTRUCTION.
- 4. MAINTAIN EXISTING VEGETATION AND EROSION CONTROL MEASURES.
- 5. CONSTRUCT FOUNDATION WALLS AND MAINTAIN THROUGHOUT CONSTRUCTION.
- 6. MAINTAIN EXISTING VEGETATION AND EROSION CONTROL MEASURES.
- 7. CONSTRUCT FOUNDATION WALLS AND MAINTAIN THROUGHOUT CONSTRUCTION.
- 8. MAINTAIN EXISTING VEGETATION AND EROSION CONTROL MEASURES.
- 9. CONSTRUCT FOUNDATION WALLS AND MAINTAIN THROUGHOUT CONSTRUCTION.
- 10. MAINTAIN EXISTING VEGETATION AND EROSION CONTROL MEASURES.
- 11. CONSTRUCT FOUNDATION WALLS AND MAINTAIN THROUGHOUT CONSTRUCTION.
- 12. MAINTAIN EXISTING VEGETATION AND EROSION CONTROL MEASURES.
- 13. A PERMITTEE SHALL SUBMIT A COPY OF THE FOLLOWING TO THE FLORIDA DEPARTMENT OF ENVIRONMENTAL PROTECTION (DPR) PRIOR TO THE START OF CONSTRUCTION:
- 14. PERMITTEE SHALL SUBMIT A COPY OF THE FOLLOWING TO THE FLORIDA DEPARTMENT OF ENVIRONMENTAL PROTECTION (DPR) PRIOR TO THE START OF CONSTRUCTION:
- 15. PERMITTEE SHALL SUBMIT A COPY OF THE FOLLOWING TO THE FLORIDA DEPARTMENT OF ENVIRONMENTAL PROTECTION (DPR) PRIOR TO THE START OF CONSTRUCTION:

STABILIZATION SCHEDULE:

PERMITTEE SHALL MAINTAIN EXISTING VEGETATION AND EROSION CONTROL MEASURES THROUGHOUT CONSTRUCTION. CONSTRUCTION SHALL ADHERE TO THE STATE OF FLORIDA DEPARTMENT OF ENVIRONMENTAL PROTECTION'S (DPR) EROSION CONTROL MEASURES.

PERMITTEE'S CERTIFICATION:

I, THE PERMITTEE, CERTIFY THAT THE INFORMATION PROVIDED HEREON IS TRUE AND CORRECT AND THAT THE PERMITTEE HAS READ AND UNDERSTANDS ALL CONDITIONS AND REQUIREMENTS OF THIS PERMIT AND HAS AGREED TO ABIDE BY ALL SUCH CONDITIONS AND REQUIREMENTS.

CONTRACTOR'S CERTIFICATION:

I, THE CONTRACTOR, CERTIFY THAT THE INFORMATION PROVIDED HEREON IS TRUE AND CORRECT AND THAT THE CONTRACTOR HAS READ AND UNDERSTANDS ALL CONDITIONS AND REQUIREMENTS OF THIS PERMIT AND HAS AGREED TO ABIDE BY ALL SUCH CONDITIONS AND REQUIREMENTS.

DATE _____

SIGNATURE _____

ADDRESS _____

CITY _____

STATE _____

PERMITTEE'S SIGNATURE _____

DATE _____

CONSTRUCTION CODE	CONSTRUCTION TYPE CODE	CONSTRUCTION TYPE CODE	CONSTRUCTION TYPE CODE
1	1	1	1
2	2	2	2
3	3	3	3
4	4	4	4
5	5	5	5
6	6	6	6
7	7	7	7
8	8	8	8
9	9	9	9
10	10	10	10
11	11	11	11
12	12	12	12
13	13	13	13
14	14	14	14
15	15	15	15
16	16	16	16
17	17	17	17
18	18	18	18
19	19	19	19
20	20	20	20
21	21	21	21
22	22	22	22
23	23	23	23
24	24	24	24
25	25	25	25
26	26	26	26
27	27	27	27
28	28	28	28
29	29	29	29
30	30	30	30
31	31	31	31
32	32	32	32
33	33	33	33
34	34	34	34
35	35	35	35
36	36	36	36
37	37	37	37
38	38	38	38
39	39	39	39
40	40	40	40
41	41	41	41
42	42	42	42
43	43	43	43
44	44	44	44
45	45	45	45
46	46	46	46
47	47	47	47
48	48	48	48
49	49	49	49
50	50	50	50

PERMITTEE SHALL MAINTAIN EXISTING VEGETATION AND EROSION CONTROL MEASURES THROUGHOUT CONSTRUCTION.

CONSTRUCTION SHALL ADHERE TO THE STATE OF FLORIDA DEPARTMENT OF ENVIRONMENTAL PROTECTION'S (DPR) EROSION CONTROL MEASURES.

DATE _____

CONTRACTOR'S SIGNATURE _____

DATE _____

CONTRACTOR'S SIGNATURE _____

DATE _____

CONTRACTOR'S SIGNATURE _____

DATE _____

CONTRACTOR'S SIGNATURE _____

DATE _____

CONTRACTOR'S SIGNATURE _____

DATE _____

CONTRACTOR'S SIGNATURE _____

DATE _____

CONTRACTOR'S SIGNATURE _____

DATE _____

CONTRACTOR'S SIGNATURE _____

DATE _____

CONTRACTOR'S SIGNATURE _____

DATE _____

CONTRACTOR'S SIGNATURE _____

DATE _____

CONTRACTOR'S SIGNATURE _____

DATE _____

CONTRACTOR'S SIGNATURE _____

DATE _____

CONTRACTOR'S SIGNATURE _____

DATE _____

CONTRACTOR'S SIGNATURE _____

DATE _____

CONTRACTOR'S SIGNATURE _____

DATE _____

CONTRACTOR'S SIGNATURE _____

DATE _____

CONTRACTOR'S SIGNATURE _____

DATE _____

CONTRACTOR'S SIGNATURE _____

DATE _____

CONTRACTOR'S SIGNATURE _____

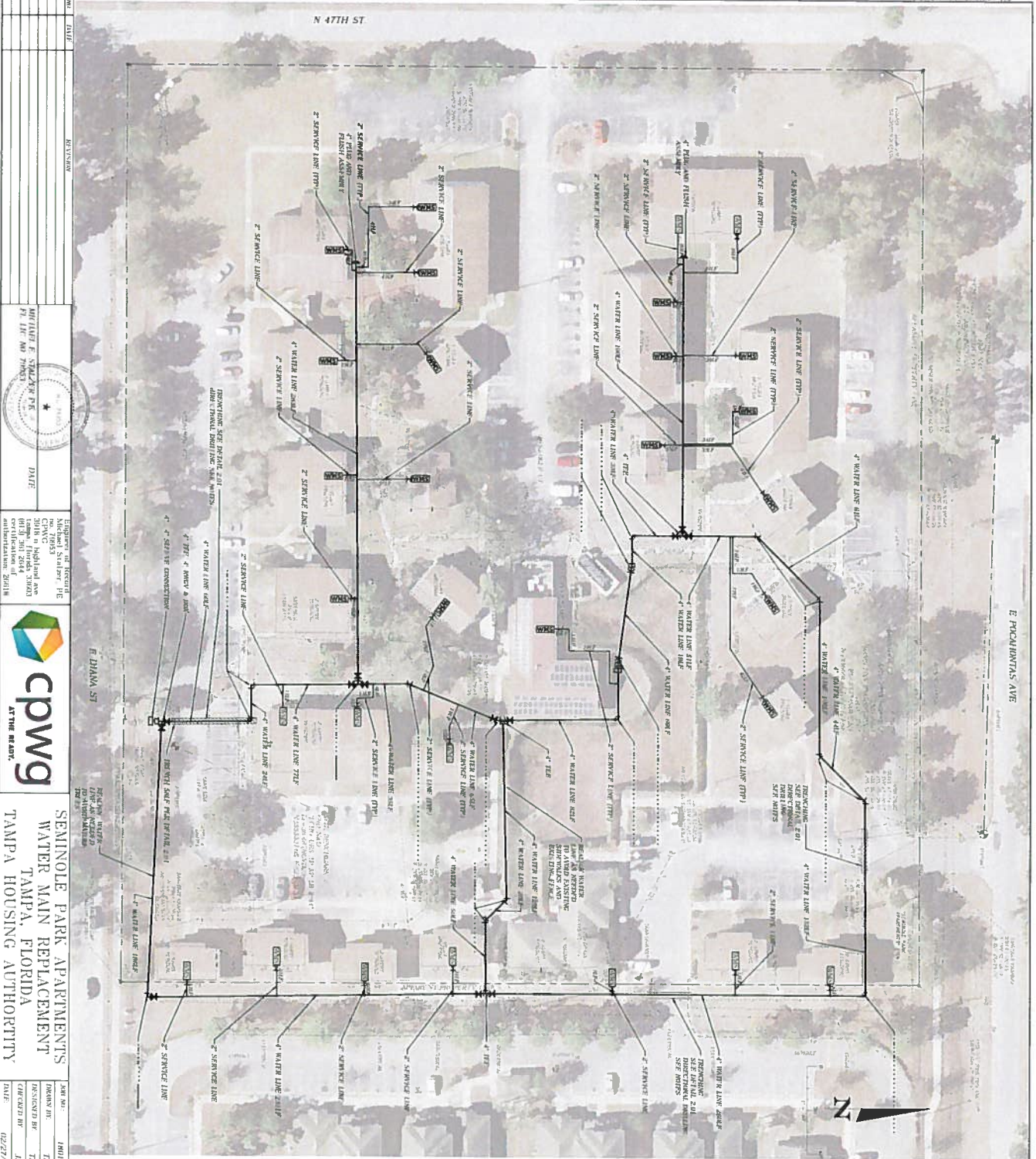

REVISIONS

NO.	DATE	DESCRIPTION
1	02/27/18	ISSUED FOR PERMITS

LEGEND

- INSTALL 2" SINKS BR STR SEPT
- PERMITS ONLY 2" SINKS BR STR SEPT
- INSTALL 2" SINKS BR STR SEPT
- PERMITS ONLY 2" SINKS BR STR SEPT

QUANTITIES

- 30 2" SINKS BR STR SEPT
- 14 2" SINKS BR STR SEPT
- 14 2" SINKS BR STR SEPT
- 14 2" SINKS BR STR SEPT

NOTES

- SEE PLAN FOR ALL EXISTING UTILITIES.
- ALL NEW UTILITIES SHALL BE INSTALLED AS SHOWN.
- ALL UTILITIES SHALL BE INSTALLED IN ACCORDANCE WITH ALL APPLICABLE CODES AND REGULATIONS.
- ALL UTILITIES SHALL BE INSTALLED IN ACCORDANCE WITH ALL APPLICABLE CODES AND REGULATIONS.
- ALL UTILITIES SHALL BE INSTALLED IN ACCORDANCE WITH ALL APPLICABLE CODES AND REGULATIONS.
- ALL UTILITIES SHALL BE INSTALLED IN ACCORDANCE WITH ALL APPLICABLE CODES AND REGULATIONS.
- ALL UTILITIES SHALL BE INSTALLED IN ACCORDANCE WITH ALL APPLICABLE CODES AND REGULATIONS.
- ALL UTILITIES SHALL BE INSTALLED IN ACCORDANCE WITH ALL APPLICABLE CODES AND REGULATIONS.
- ALL UTILITIES SHALL BE INSTALLED IN ACCORDANCE WITH ALL APPLICABLE CODES AND REGULATIONS.
- ALL UTILITIES SHALL BE INSTALLED IN ACCORDANCE WITH ALL APPLICABLE CODES AND REGULATIONS.

PROJECT NO.	180143
ISSUED BY	TJC
DESIGNED BY	TJC
CHECKED BY	JHN
DATE	02/27/18
UTILITY PLAN	
SHEET NO.	C05
OF	7



SEMINOLE PARK APARTMENTS
 WATER MAIN REPLACEMENT
 TAMPA, FLORIDA
 TAMPA HOUSING AUTHORITY

DATE: _____
 REVISION: _____

NO.	DATE	DESCRIPTION
1		
2		
3		

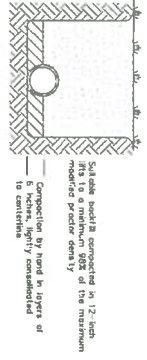

1. Type 2 trench is defined as a full-bottom trench.
 2. The standard must be utilized in the absence of specific standards. The standard of the agency directed by the Engineer.
 3. Saddle blocks may be defined on marked free faces of streets or other marked that in the opinion of the Engineer is unworkable.

TAMPA WATER DEPARTMENT	APPROVED	REVISION	TYPICAL REINFORCING BEDDING FOR NON-PAVED AREAS	2.02
------------------------	----------	----------	---	------

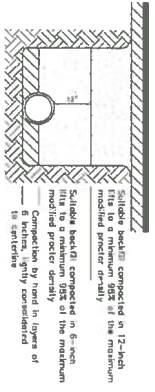

1. Type 2 trench is defined as a full-bottom trench.
 2. The standard must be utilized in the absence of specific standards. The standard of the agency directed by the Engineer.
 3. Saddle blocks may be defined on marked free faces of streets or other marked that in the opinion of the Engineer is unworkable.

TAMPA WATER DEPARTMENT	APPROVED	REVISION	TYPICAL REINFORCING BEDDING AND BASEBALL DETAIL FOR PAVED AREAS	2.01
------------------------	----------	----------	---	------

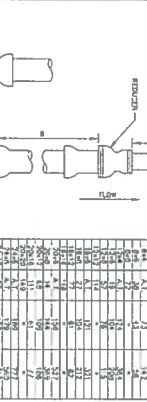

1. The hole is 12 inches in diameter.
 2. The hole is 12 inches deep.
 3. The hole is 12 inches wide.
 4. The hole is 12 inches high.
 5. The hole is 12 inches long.
 6. The hole is 12 inches wide.
 7. The hole is 12 inches high.
 8. The hole is 12 inches long.
 9. The hole is 12 inches wide.
 10. The hole is 12 inches high.

TAMPA WATER DEPARTMENT	APPROVED	REVISION	RESTRIAINED JOINT STANDARD FOR TIES AND WEDGES	2.12
------------------------	----------	----------	--	------

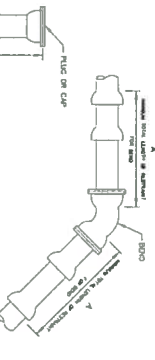

1. The hole is 12 inches in diameter.
 2. The hole is 12 inches deep.
 3. The hole is 12 inches wide.
 4. The hole is 12 inches high.
 5. The hole is 12 inches long.
 6. The hole is 12 inches wide.
 7. The hole is 12 inches high.
 8. The hole is 12 inches long.
 9. The hole is 12 inches wide.
 10. The hole is 12 inches high.

TAMPA WATER DEPARTMENT	APPROVED	REVISION	RESTRIAINED JOINT STANDARD FOR TIES AND WEDGES	2.11
------------------------	----------	----------	--	------



1. The hole is 12 inches in diameter.
 2. The hole is 12 inches deep.
 3. The hole is 12 inches wide.
 4. The hole is 12 inches high.
 5. The hole is 12 inches long.
 6. The hole is 12 inches wide.
 7. The hole is 12 inches high.
 8. The hole is 12 inches long.
 9. The hole is 12 inches wide.
 10. The hole is 12 inches high.

TAMPA WATER DEPARTMENT	APPROVED	REVISION	TYPICAL GATE VALVE VALVE BOX AND PAD INSTALLATION	3.01
------------------------	----------	----------	---	------

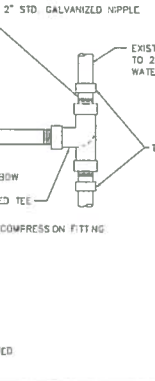

1. The hole is 12 inches in diameter.
 2. The hole is 12 inches deep.
 3. The hole is 12 inches wide.
 4. The hole is 12 inches high.
 5. The hole is 12 inches long.
 6. The hole is 12 inches wide.
 7. The hole is 12 inches high.
 8. The hole is 12 inches long.
 9. The hole is 12 inches wide.
 10. The hole is 12 inches high.

TAMPA WATER DEPARTMENT	APPROVED	REVISION	TAPPED CONNECTION FOR 2" W/ 2" W/ 2" WATER MAINS	2.13
------------------------	----------	----------	--	------

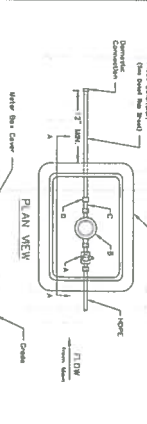

1. The hole is 12 inches in diameter.
 2. The hole is 12 inches deep.
 3. The hole is 12 inches wide.
 4. The hole is 12 inches high.
 5. The hole is 12 inches long.
 6. The hole is 12 inches wide.
 7. The hole is 12 inches high.
 8. The hole is 12 inches long.
 9. The hole is 12 inches wide.
 10. The hole is 12 inches high.

TAMPA WATER DEPARTMENT	APPROVED	REVISION	METER SET DETAIL	5.02
------------------------	----------	----------	------------------	------

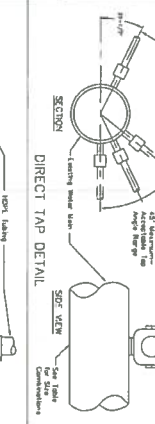

1. The hole is 12 inches in diameter.
 2. The hole is 12 inches deep.
 3. The hole is 12 inches wide.
 4. The hole is 12 inches high.
 5. The hole is 12 inches long.
 6. The hole is 12 inches wide.
 7. The hole is 12 inches high.
 8. The hole is 12 inches long.
 9. The hole is 12 inches wide.
 10. The hole is 12 inches high.

TAMPA WATER DEPARTMENT	APPROVED	REVISION	TAPPING DETAIL FOR CORPORATION STOP	5.01
------------------------	----------	----------	-------------------------------------	------

DATE: 02/27/14

DESIGNED BY: JEN

CHECKED BY: JEN

PROJECT NO: 180143

PROJECT NAME: TAMPA HOUSING AUTHORITY

PROJECT LOCATION: TAMPA, FLORIDA

PROJECT TYPE: WATER MAIN REPLACEMENT

PROJECT PHASE: SEMINOLE PARK APARTMENTS

PROJECT STATUS: IN PROGRESS

PROJECT CONTACT: TAMPA WATER DEPARTMENT

PROJECT ADDRESS: TAMPA, FLORIDA

PROJECT PHONE: (813) 274-1234

PROJECT FAX: (813) 274-1234

PROJECT EMAIL: TAMPA@TAMPAFLORIDA.GOV

PROJECT WEBSITE: WWW.TAMPAFLORIDA.GOV

PROJECT LOGO: cpwpg AT THE READY.

SHEET NO: C06

TOTAL SHEETS: 7



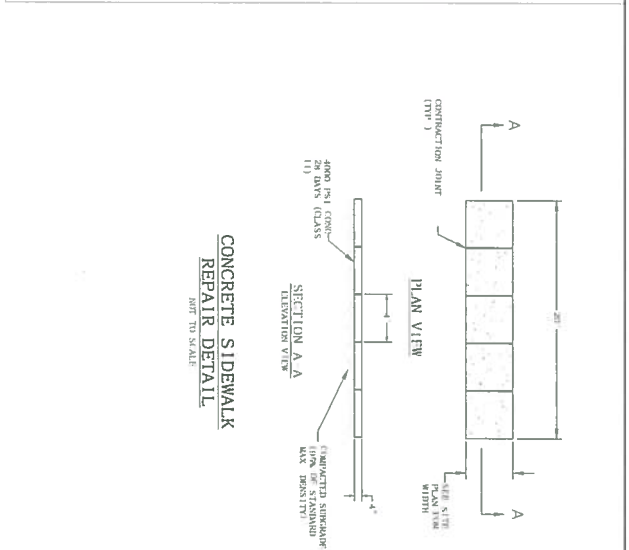
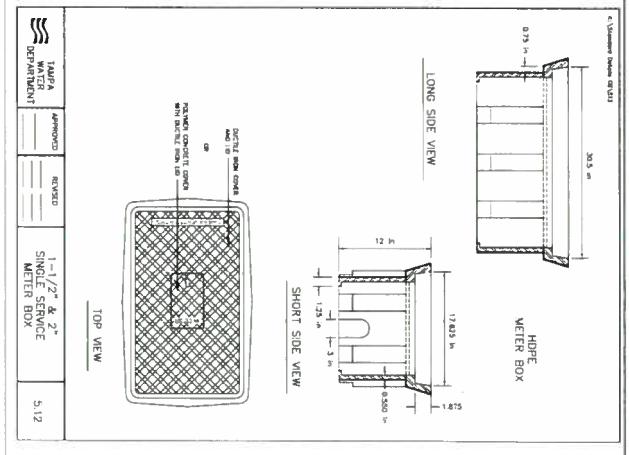

LOCATION OF PUBLIC WATER SYSTEM MAINS IN ACCORDANCE WITH F.A.C. RULE 62-555.314

Other Pipe	Horizontal Separation	Clearance (1)	Joint Spacing & Clearings (2) All Joint Centers
Storm Sewer, Sanitary Sewer, Stormwater Force Mains, Recycled Water (1)	Water Mains 1.8' minimum	Water Mains 1.8' minimum 1.5' minimum in wet weather 1.2' minimum in dry weather	Alternate A & B minimum
Vertical Sewer	Water Mains 1.8' minimum	Water Mains 1.8' minimum 1.5' minimum in wet weather 1.2' minimum in dry weather	Alternate A & B minimum
Vertical Sewer	Water Mains 1.8' minimum	Water Mains 1.8' minimum 1.5' minimum in wet weather 1.2' minimum in dry weather	Alternate A & B minimum

Horizontal Separation
 (1) Water mains shall cross above other pipe. When a water main must be below other pipe, the minimum separation is 12 inches.
 (2) A 6" or greater sanitary sewer shall be below other pipe, the minimum separation is 12 inches.
 (3) A 6" or greater storm sewer shall be below other pipe, the minimum separation is 12 inches.
 (4) Recycled water not regulated under Part III of Chapter 62-540, F.A.C.

Clearance (1)
 (1) Water mains shall be installed at least 1.8' above the ground surface.
 (2) Water mains shall be installed at least 1.5' above the ground surface in wet weather and 1.2' above the ground surface in dry weather.

Joint Spacing & Clearings (2) All Joint Centers
 (1) Water mains shall be installed at least 1.8' above the ground surface.
 (2) Water mains shall be installed at least 1.5' above the ground surface in wet weather and 1.2' above the ground surface in dry weather.

Alternate A & B minimum
 (1) Water mains shall be installed at least 1.8' above the ground surface.
 (2) Water mains shall be installed at least 1.5' above the ground surface in wet weather and 1.2' above the ground surface in dry weather.

DATE	REVISION	DATE

RICHARD E. SMITH
 P.E.
 No. 12478
 State of Florida

SEMINOLE PARK APARTMENTS
 WATER MAIN REPLACEMENT
 TAMPA, FLORIDA
 TAMPA HOUSING AUTHORITY

DATE	02/27/14
DESIGNED BY	TAD
CHECKED BY	JEN
DATE	02/27/14
SHEET NO	18014
PROJECT NO	TAD
DATE	02/27/14
DETAILS	(02)
SHEET NO	C07
DATE	02/27/14

**TOPOGRAPHIC SURVEY OF
SEMINOLE APARTMENTS
TAMPA, FLORIDA**
LYING IN A PORTION OF
SECTION 33, TOWNSHIP 28 SOUTH, RANGE 19 EAST
HILLSBOROUGH COUNTY, FLORIDA

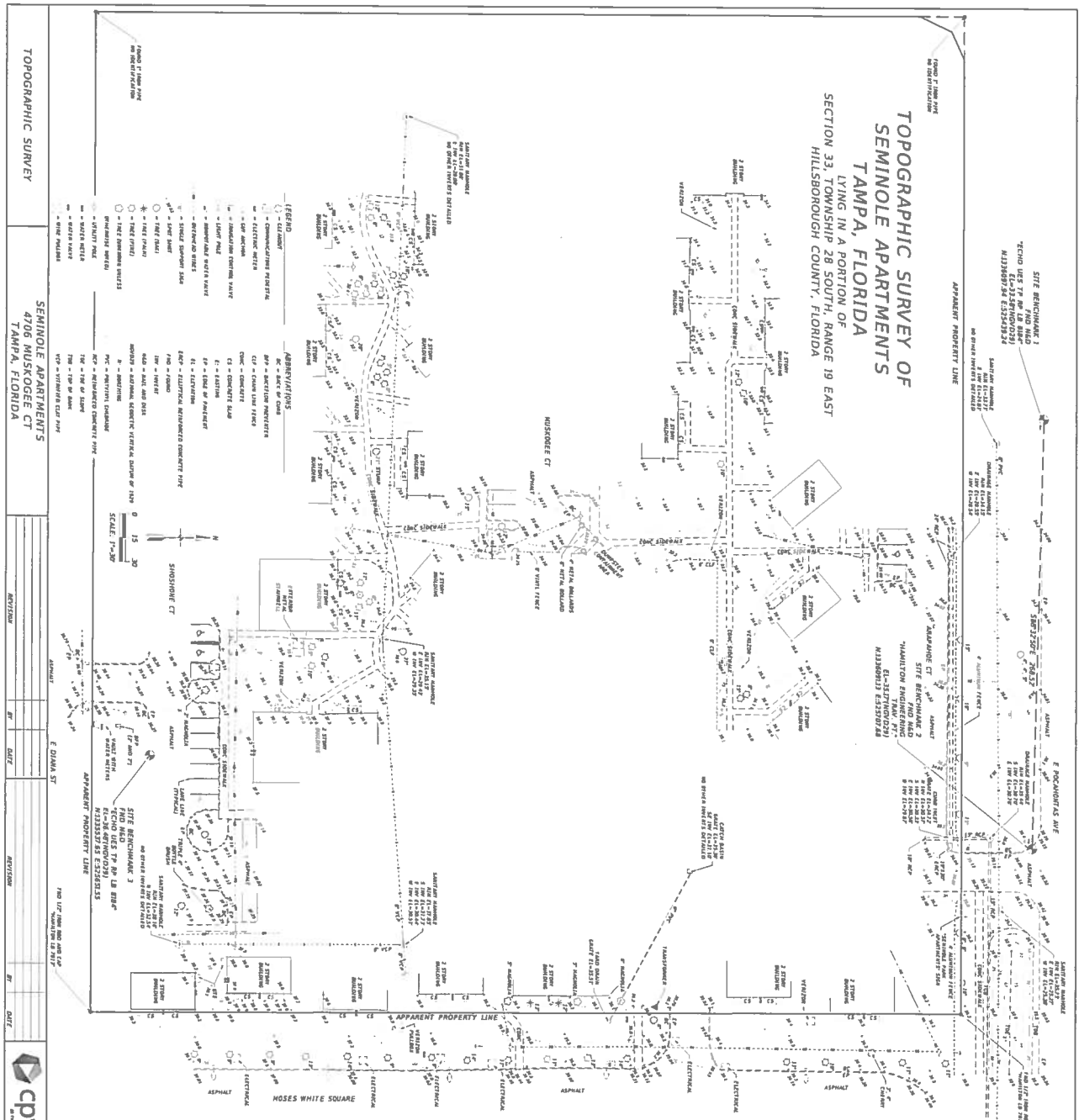

REVOLUTION	BY	DATE

TOPOGRAPHIC SURVEY

**SEMINOLE APARTMENTS
4706 MOSKOWE CT
TAMPA, FLORIDA**

2018 N. HIGHLAND AVENUE TAMPA, FLORIDA 33604
REGISTERED PROFESSIONAL SURVEYOR & MAPPER
NORTHWEST CORNER NUMBER 8262412

PROJECT NUMBER	DATE

SCALE 1"=30'

SHEET 501 OF 501

LOCATION MAP

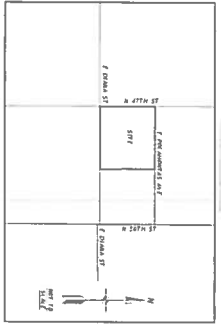

SURVEYORS' REPORT

1. THE PURPOSE OF THIS SURVEY IS TO ESTABLISH THE HORIZONTAL AND VERTICAL SPATIAL RELATIONSHIP OF THE BUILDING OR MANMADE FEATURES (LINE) WITHIN THE TOPOGRAPHIC SURVEY SHOWN HEREON.
2. BEGINNINGS AND COORDINATES SHOWN HEREON ARE RELATIVE TO THE FLORIDA STATE PLANE COORDINATE BEARING OF SOUTH 89°52'08" EAST BEING THE STATE PLANE COORDINATE NORTH TOWNSHIP 28 SOUTH RANGE 19 EAST BEING THE KERMATIC TRIANGULAR POSITIONING SYSTEM (KTPS) USING THE FLORIDA ACQUADAMMO FOR HORIZONTAL CONTROL AND THE NATIONAL GEODETIC REFERENCE SYSTEM (NAD83) USING THE HORIZONTAL CONTROL.
3. ELEVATIONS SHOWN HEREON ARE RELATIVE TO THE NATIONAL GEODETIC REFERENCE SYSTEM OF 1989 HORIZONTAL ENGINEERING & SURVEYING, INC. PREPARED FOR TAMPA HOUSING AUTHORITY, JOB NUMBER 20-0566/20-0700-2, PUBLISHED ELEVATION OF 39.98 FEET (NOVEMBER).
4. HORIZONTAL POSITION INFORMATION FOR VERTICAL CONTROL POINTS, IS SHOWN TO THE NEAREST FOOT FOR FIELD USE AS HORIZONTAL CONTROL.
5. A ROUTINE SURVEY WAS NOT INCURRED AS PART OF THIS PROJECT. THE APARENT PROPERTY LINES SHOWN HEREON ARE BASED ON LIMITED FIELD MEASUREMENT AND IS SHOWN FOR INFORMATIONAL PURPOSES ONLY.
6. THE SURVEYOR HAS NOT ABSTRACTED THE LANDS SHOWN HEREON FOR EXISTING AND/OR RIGHT-OF-WAY RECORDS. THIS SURVEY WAS PERFORMED WITHOUT THE BENEFIT OF A TITLE REPORT.
7. NO UNDERGROUND UTILITIES LINES (IF ANY) WERE LOCATED AS PART OF THIS SURVEY.
8. UNLESS IT BEARS THE SIGNATURE AND THE ORIGINAL METERS SEAL OF A LICENSED SURVEYOR AND MAPPER, THIS DRAWING, SPECIFICALLY, MAY BE USED FOR INFORMATIONAL PURPOSES ONLY AND IS NOT VALID FOR OBTAINING RECALLED INFORMATION.
9. THIS SURVEY MAY HAVE BEEN REPRODUCED IN SIZE OR REPRODUCTION. THIS MUST BE CONSIDERED WHEN ADDITIONS OR DELETIONS TO THIS SURVEY AND/OR GENERAL NOTES BY ANY OTHER THAN THE SURVEYOR AND MAPPER IN RESPONSIBLE CHANGE, AND PROHIBITED WITHOUT THE EXPRESS WRITTEN CONSENT OF THE SURVEYOR AND MAPPER IN RESPONSIBLE CHANGE.
10. THESE 9" IN DIAMETER AND LARGER HAVE BEEN LOCATED WITH COMPOUND NAME AND APPROXIMATE DIAMETER. THESE 6" IN DIAMETER AND SMALLER HAVE BEEN LOCATED WITH SINGLE NAME AND APPROXIMATE DIAMETER. THE TREE LOCATION IS THE CENTER OF THE TREE. THIS LOCATION MAY DIFFER IF LOCATED FROM THE PROJECT OR AND THESE WERE NOT LOCATED AS PART OF THIS SURVEY.
11. LAST DATE OF FIELD SURVEY: JANUARY 23, 2019

**PREPARED FOR:
TAMPA HOUSING AUTHORITY**

SURVEYORS' CERTIFICATION

I, THE SURVEYOR, HEREBY CERTIFY THAT I AM A LICENSED SURVEYOR AND MAPPER IN THE STATE OF FLORIDA AND I AM THE ONLY SURVEYOR AND MAPPER WHO HAS CONDUCTED THIS SURVEY AND I AM NOT PROVIDING THIS SURVEY TO ANY OTHER PARTY WITHOUT THE WRITTEN CONSENT OF THE FLORIDA SURVEYORS' BOARD. I HAVE READ AND UNDERSTAND THE CONTENTS OF THIS REPORT AND I HAVE AGREED TO BE BOUND BY THE TERMS AND CONDITIONS SET FORTH HEREIN.

DATE: 01-23-2019

PROJECT NUMBER: 10411

NAME OF SURVEYOR: CPWG

DATE OF SURVEY: 01-23-2019

CONTRACT NUMBER: 2018000002

BID FORM

Seminole Park Apartment Water Main Replacement

IFB FY19-IFB-01

Attention:

The undersigned, having familiarized (him/herself) (themselves) with the local conditions affecting the cost of the work, and with the Detailed Scope of Work, including the Invitation to Bid; Instructions to Bidders, this Bid Form, the form of the Non-Collusive Affidavit; the form of the General Conditions; the Special Conditions; the Wage Determination, the Technical Specifications, The Construction Drawings, Addenda, if any and any other associated forms or documents thereto, on file in the Office of the Housing Authority, hereby proposes to furnish all labor, equipment, services, licenses, permits and material required, complete with all associated work required by the plans and specifications. Questions concerning bid documents shall be directed to the Housing Authority by e-mailing bidderquestions@thaf1.com.

The following principles shall govern the competitive bidding process:

1. The Housing Authority will award the contract to the acceptable Contractor submitting the lowest responsive **Total Base Bid Amount**.
2. In the event an error is made totaling amounts listed on the bid form the award will be made on the basis of amounts correctly extended.
3. Bidders are required to bid on all items requested on the Bid Form. Failure to provide all information requested shall render the bid non-responsive.
4. All questions concerning the bid documents requiring additional information or clarification shall be submitted in writing to THA via e-mail at bidderquestions@thaf1.com. All questions will be accepted until **Friday, April 19, 2019** and responded to in writing with addendum(s) issued to all prospective bidders.
5. The Housing Authority reserves the right to activate any alternate bids for a period of sixty days subsequent to the date of contract award.
6. All prices and information required on the bid form must be typewritten or written legibly in ink.
7. Any stipulations made as to the bidder's bid shall subject the bid to rejection. If bidder wishes to include additional information, bidder may do so with attachments. However, alternate proposals will not be considered unless specifically requested in these specifications.



-
8. Any bidder having a complaint or protest regarding this bid must submit the complaint or protest in writing to the Housing Authority's Contracting Officer eight (8) or more days prior to the date set for opening of bids. Any bidder protesting a bid opening must submit the protest in writing to the contracting officer no later than three (3) days after bid opening for the protest to be considered.

BIDDER agrees to perform all the work described in these Contract Documents for **Seminole Park Apartments Water Main Replacement:**

Total Base Bid Amount: \$ _____



Subcontractor List: The Housing Authority requires bidders to identify subcontractors that have provided proposals for this bid and who may be considered if the contractor is the bid winner. This list of subcontractors shall demonstrate the level of commitment to achieving the Authority's stated MBE and Section 3 goals. The Authority realizes that firm commitments will not be made by the General Contractor until after the GC is announced as the successful bidder. The subcontractors on the list may therefore be modified by the GC subject to review by the Authority.

Subcontractor Name & Address	Type of Work Classification	Approx. Amount	License #	Ownership (check)		
				MBE	SECT. 3	LOCAL

ADD ADDITIONAL PAGES AS NECESSARY

- MBE** - Minority Business Enterprise as defined in Section 00810
- Section 3** - Section 3 Business Concern as defined in Section 00810
- Local** - A business who has a local, City of Tampa or Hillsborough County business office address.



ADDENDA:

Bidder hereby acknowledges the following addenda issued during the bidding period:

Addendum # 1 issued, _____
(enter date of addendum, if any)

Addendum #2 issued, _____
(enter date of addendum, if any)

In submitting this bid it is understood that the right is reserved by the Housing Authority to reject any and all bids. If written notice of the acceptance of this bid is mailed, telegraphed, or delivered to the undersigned within sixty (60) consecutive calendar days after the opening thereof, or at any time thereafter, before this bid is withdrawn, the undersigned agree to execute and deliver a contract in the prescribed form and furnish the required bond within ten (10) consecutive calendar days after the contract is presented to him/her for signature.

DATE _____ NAME OF BIDDER _____

SEAL BY _____

TITLE _____

ADDRESS _____

STATE OF _____ PHONE _____

CITY OF _____ FEDERAL I.D. NUMBER _____

Subscribed and sworn to me this _____ day of _____ 20____

NOTARY PUBLIC

My Commission expires _____



BID BOND

Bond No: _____

KNOW ALL MEN BY THESE PRESENTS, That we, the undersigned

(Name of Principal)

as PRINCIPAL (hereinafter called "Principal"), and

(Name of Surety)

as SURETY (hereinafter called "Surety"), are hereby held and firmly bound unto the HOUSING AUTHORITY OF THE CITY OF TAMPA (hereinafter called "AUTHORITY") for the penal sum of _____ DOLLARS, lawful money of the United States, for the payment of which sum well and truly to be made, we hereby jointly and severally bind ourselves, our heirs, executors, administrators, personal representatives, successors and assigns, jointly and severally, firmly by these presents.

THE CONDITION OF THIS OBLIGATION IS SUCH that whereas the Principal has submitted an accompanying bid dated _____, 20____ for the Project Contract number

(Insert Job Number)

NOW, THEREFORE, if the Principal shall not withdraw said bid within the period specified therein after the opening of the same, or, if no period be specified, within sixty (60) days after said opening, and shall in the period specified therefore, or if no period be specified, within ten (10) days after the prescribed forms are presented to him for signature, enter into a written contract with the Authority in accordance with the bids as accepted, and give bond with good and sufficient surety or sureties, as may be required for the faithful performance and proper fulfillment of such contract; or in the event of withdrawal of said bid within the period specified, or the failure to enter into such contract and give such bond within the time specified, the Principal shall pay the Authority the difference between the amount specified in said bid and the amount for which the Authority may procure the required work or supplies or both, if the latter amount be in excess of the former, then the above obligation shall be void and of no effect, otherwise to remain in full force and virtue.

IN WITNESS WHEREOF, the above bound parties have executed this instrument under their seals this _____ day of _____, 20____, the name and corporate seal of each corporate party being hereto affixed and these presents duly signed by its undersigned representative, pursuant to authority of its governing body.



In presence of:

(Attest)

(Individual Principal) (Seal)

(Business Address)

(Attest)

(Individual Principal) (Seal)

(Business Address)

By _____ Affix Corporate Seal

(Attest:)

(Attest:)

(Corporate Surety)

By _____ Affix Corporate Seal

(Power of Attorney for person signing for Surety Company must be attached to bond)

CERTIFICATE AS TO CORPORATE PRINCIPAL

I, _____ certify that I am the

Secretary of the corporation named as Principal in the within bond: That

who signed the bond on behalf of the Principal , was then

of said corporation; that I know his/her/her signature thereto is genuine; and that said bond was duly signed, sealed, and attested to for and in behalf of said corporation by authority of its governing body

_____ (Corporate Seal).

This Page is intentionally Left Blank

END OF BID BOND

Representations, Certifications, and Other Statement of Bidders - Public and Indian Housing Programs

Table of Contents

Clause	Page
1. Certificate of Independent Price Determination	1
2. Contingent Fee Representation and Agreement	1
3. Certification and Disclosure Regarding Payments to Influence Certain Federal Transactions	2
4. Organizational Conflicts of Interest Certification	2
5. Bidder's Certification of Eligibility	2
6. Minimum Bid Acceptance Period	2
7. Small, Minority, Women-Owned Business Concern Representation	3
8. Indian Owned Economic Enterprise and Indian Organization Representation	3
9. Certification of Eligibility Under the Davis-Bacon Act	3
10. Certification of Nonsegregated Facilities	3
11. Clean Air and Water Certification	4
12. Bidder's Signature	4

1. Certificate of Independent Price Determination

(a) The bidder certifies that -

(1) The prices in this bid have been arrived at independently, without, for the purpose of restricting competition, any consultation, communication, or agreement with any other bidder of competitor relating to (i) those prices, (ii) the intention to submit a bid, or (iii) the methods or factors used to calculate the prices offered;

(2) The prices in this bid have not been and will not be knowingly disclosed by the bidder, directly or indirectly, to any other bidder or competitor before bid opening (in the case of a sealed bid solicitation) or contract award (in the case of a competitive proposal solicitation) unless otherwise required by law; and

(3) No attempt has been made or will be made by the bidder to induce any other concern to submit or not to submit a bid for the purpose of restricting competition.

(b) Each signature on the bid is considered to be a certification by the signatory that the signatory -

(1) Is the person in the bidder's organization responsible for determining the prices being offered in this bid or proposal, and that the signatory has not participated and will not participate in any action contrary to subparagraphs (a) (1) through (a)(3) above; or

(2) (i) Has been authorized, in writing, to act as agent for the following principals in certifying that those principals have not participated, and will not participate in any action contrary to subparagraphs (a)(1) through (a)(3) above.

_____ [insert full name of person(s) in the bidder's organization responsible for determining the prices offered in this bid or proposal, and the title of his or her position in the bidder's organization];

(ii) As an authorized agent, does certify that the principals named in subdivision (b)(2)(i) have not participated, and will not participate, in any action contrary to subparagraphs (a)(1) through (a)(3) above; and

(iii) As an agent, has not personally participated, and will not participate in any action contrary to subparagraphs (a)(1) through (a)(3) above.

(c) If the bidder deletes or modifies subparagraph (a)2 above, the bidder must furnish with its bid a signed statement setting forth in detail the circumstances of the disclosure.

[Contracting Officer check if following paragraph is applicable]

(d) Non-collusive affidavit. (Applicable to contracts for construction and equipment exceeding \$50,000)

(1) Each bidder shall execute, in the form provided by the PHA/IHA, an affidavit to the effect that he/she has not colluded with any other person, firm or corporation in regard to any bid submitted in response to this solicitation. If the successful bidder did not submit the affidavit with his/her bid, he/she must submit it within three (3) working days of bid opening. Failure to submit the affidavit by that date may render the bid nonresponsive. No contract award will be made without a properly executed affidavit.

(2) A fully executed "Non-collusive Affidavit" [] is, [] is not included with this bid.

2. Contingent Fee Representation and Agreement

(a) Definitions. As used in this provision:

"Bona fide employee" means a person, employed by a bidder and subject to the bidder's supervision and control as to time, place, and manner of performance, who neither exerts, nor proposes to exert improper influence to solicit or obtain contracts nor holds out as being able to obtain any contract(s) through improper influence.

"Improper influence" means any influence that induces or tends to induce a PHA/IHA employee or officer to give consideration or to act regarding a PHA/IHA contract on any basis other than the merits of the matter.

(b) The bidder represents and certifies as part of its bid that, except for full-time bona fide employees working solely for the bidder, the bidder:

(1) has, has not employed or retained any person or company to solicit or obtain this contract; and

(2) has, has not paid or agreed to pay to any person or company

employed or retained to solicit or obtain this contract any commission, percentage, brokerage, or other fee contingent upon or resulting from the award of this contract.

(c) If the answer to either (a)(1) or (a)(2) above is affirmative, the bidder shall make an immediate and full written disclosure to the PHA/IHA Contracting Officer.

(d) Any misrepresentation by the bidder shall give the PHA/IHA the right to (1) terminate the contract; (2) at its discretion, deduct from contract payments the amount of any commission, percentage, brokerage, or other contingent fee; or (3) take other remedy pursuant to the contract.

3. Certification and Disclosure Regarding Payments to Influence Certain Federal Transactions (applicable to contracts exceeding \$100,000)

(a) The definitions and prohibitions contained in Section 1352 of title 31, United States Code, are hereby incorporated by reference in paragraph (b) of this certification.

(b) The bidder, by signing its bid, hereby certifies to the best of his or her knowledge and belief as of December 23, 1989, that:

(1) No Federal appropriated funds have been paid or will be paid to any person for influencing or attempting to influence an officer or employee of any agency, a Member of Congress, an officer or employee of Congress, or an employee of a Member of Congress on his or her behalf in connection with the awarding of a contract resulting from this solicitation;

(2) If any funds other than Federal appropriated funds (including profit or fee received under a covered Federal transaction) have been paid, or will be paid, to any person for influencing or attempting to influence an officer or employee of any agency, a Member of Congress, an officer or employee of any agency, a Member of Congress, an officer or employee of Congress, or an employee of a Member of Congress on his or her behalf in connection with this solicitation, the bidder shall complete and submit, with its bid, OMB standard form LLL, "Disclosure of Lobbying Activities;" and

(3) He or she will include the language of this certification in all subcontracts at any tier and require that all recipients of subcontract awards in excess of \$100,000 shall certify and disclose accordingly.

(c) Submission of this certification and disclosure is a prerequisite for making or entering into this contract imposed by section 1352, title 31, United States Code. Any person who makes expenditure prohibited under this provision or who fails to file or amend the disclosure form to be filed or amended by this provision, shall be subject to a civil penalty of not less than \$10,000, and not more than \$100,000, for each such failure.

(d) Indian tribes (except those chartered by States) and Indian organizations as defined in section 4 of the Indian Self-Determination and Education Assistance Act (25 U.S.C. 450B) are exempt from the requirements of this provision

4. Organizational Conflicts of Interest Certification

The bidder certifies that to the best of its knowledge and belief and except as otherwise disclosed, he or she does not have any organizational conflict of interest which is defined as a situation in which the nature of work to be performed under this proposed contract and the bidder's organizational, financial, contractual, or other interests may, without some restriction on future activities:

- (a) Result in an unfair competitive advantage to the bidder; or
- (b) Impair the bidder's objectivity in performing the contract work.

[] In the absence of any actual or apparent conflict, I hereby certify that to the best of my knowledge and belief, no actual or apparent conflict of interest exists with regard to my possible performance of this procurement.

5. Bidder's Certification of Eligibility

(a) By the submission of this bid, the bidder certifies that to the best of its knowledge and belief, neither it, nor any person or firm which has an interest in the bidder's firm, nor any of the bidder's subcontractors, is ineligible to:

(1) Be awarded contracts by any agency of the United States Government, HUD, or the State in which this contract is to be performed; or,

(2) Participate in HUD programs pursuant to 24 CFR Part 24.

(b) The certification in paragraph (a) above is a material representation of fact upon which reliance was placed when making award. If it is later determined that the bidder knowingly rendered an erroneous certification, the contract may be terminated for default, and the bidder may be debarred or suspended from participation in HUD programs and other Federal contract programs.

6. Minimum Bid Acceptance Period

(a) "Acceptance period", as used in this provision, means the number of calendar days available to the PHA/IHA for awarding a contract from the date specified in this solicitation for receipt of bids.

(b) This provision supersedes any language pertaining to the acceptance period that may appear elsewhere in this solicitation.

(c) The PHA/IHA requires a minimum acceptance period of sixty (60) consecutive calendar days.

(d) In the space provided immediately below, bidders may specify a longer acceptance period than the PHA's/IHA's minimum requirement. The bidder allows the following acceptance period: _____ calendar days.

(e) A bid allowing less than the PHA's/IHA's minimum acceptance period will be rejected.

(f) The bidder agrees to execute all that it has undertaken to do, in compliance with the bid, if that bid is accepted in writing within (1) the acceptance period stated in paragraph (c) above or (2) any longer acceptance period stated in paragraph (d) above.

7. Small, Minority, Women-Owned Business Concern Representation

The bidder represents and certifies as part of its bid/offer that it -

(a) is, is not a small business concern. "Small business concern," as used in this provision, means a concern, including its affiliates, that is independently owned and operated, not dominant in the field of operation in which it is bidding, and qualified as a small business under the criteria and size standards in 13 CFR 121.

(b) is, is not a women-owned business enterprise. "Women-owned business enterprise," as used in this provision, means a business that is at least 51 percent owned by a woman or women who are U.S. citizens and who also control and operate the business.

(c) is, is not a minority business enterprise. "Minority business enterprise," as used in this provision, means a business which is at least 51 percent owned or controlled by one or more minority group members or, in the case of a publicly-owned business, at least 51 percent of its voting stock is owned by one or more minority group members, and whose management and daily operations are controlled by one or more such individuals. For the purpose of this definition, minority group members are:

(Check the block applicable to you)

- Black Americans
- Asian Pacific Americans
- Hispanic Americans
- Asian Indian Americans
- Native Americans
- Hasidic Jewish Americans

8. Indian-Owned Economic Enterprise and Indian Organization Representation

(applicable only if this solicitation is for a contract to be performed on a project for an Indian Housing Authority)

The bidder represents and certified that it:

(a) is, is not an Indian-owned economic enterprise. "Economic enterprise," as used in this provision, means any commercial, industrial, or business activity established or organized for the purpose of profit, which at least 51 percent Indian is owned. "Indian," as used in this provision, means any person who is a member of any tribe, band, group, pueblo, or community which is recognized by the Federal Government as eligible for services for the Bureau of Indian Affairs and "Native" as defined in the Alaska Native Claims Settlement Act.

(b) is, is not an Indian organization. "Indian organization," as used in this provision, means the governing body of any Indian tribe or entity established or recognized by such governing body. Indian "tribe" means any Indian tribe, band, group, pueblo, or community including Native villages and Native groups (including corporations organized by Kenai, Juneau, Sitka, and Kodiak) as defined in the Alaska Native Claims Settlement Act, which is recognized by the Federal Government as eligible for services from the Bureau of Indian Affairs.

9. Certification of Eligibility Under the Davis-

Bacon Act (applicable to construction contracts exceeding \$2,000)

a. By the submission of this bid, the bidder certifies that neither it nor any person or firm who has an interest in the bidder's firm is a person or firm ineligible to be awarded contracts by the United States Government by virtue of section 3(a) of the Davis-Bacon Act or 29 CFR 5.12(a)(1).

(b) No part of the contract resulting from this solicitation shall be subcontracted to any person or firm ineligible to be awarded contracts by the United States Government by virtue of section 3(a) of the Davis-Bacon Act or 29 CFR 5.12(a)(1).

(c) The penalty for making false statements is prescribed in the U.S. Criminal Code, 18 U.S.C. 1001.

10. Certification of Nonsegregated Facilities (applicable to contracts exceeding \$10,000)

(a) The bidder's attention is called to the clause entitled **Equal Employment Opportunity** of the General Conditions of the Contract for Construction.

(b) "Segregated facilities," as used in this provision, means any waiting rooms, work areas, rest rooms and wash rooms, restaurants and other eating areas, time clocks, locker rooms and other storage or dressing areas, parking lots, drinking fountains, recreation or entertainment areas, transportation, and housing facilities provided for employees, that are segregated by explicit directive or are in fact segregated on the basis of race, color, religion, or national origin because of habit, local custom, or otherwise.

(c) By the submission of this bid, the bidder certifies that it does not and will not maintain or provide for its employees any segregated facilities at any of its establishments, and that it does not and will not permit its employees to perform their services at any location under its control where segregated facilities are maintained. The bidder agrees that a breach of this certification is a violation of the Equal Employment Opportunity clause in the contract.

(d) The bidder further agrees that (except where it has obtained identical certifications from proposed subcontractors for specific time periods) prior to entering into subcontracts which exceed \$10,000 and are not exempt from the requirements of the Equal Employment Opportunity clause, it will -

- (1) Obtain identical certifications from the proposed subcontractors;
- (2) Retain the certifications in its files; and
- (3) Forward the following notice to the proposed subcontractors (except if the proposed subcontractors have submitted identical certifications for specific time periods:

11. Notice to Prospective Subcontractors of Requirement for



Certifications of Nonsegregated Facilities

A Certification of Nonsegregated Facilities must be submitted before the award of a subcontract exceeding \$10,000 which is not exempt from the provisions of the Equal Employment Opportunity clause of the prime contract. The certification may be submitted either for each subcontract or for all subcontracts during a period (i.e., quarterly, semiannually, or annually).

Note: The penalty for making false statements in bids is prescribed in 18 U.S.C. 1001.

12. Clean Air and Water Certification (applicable to contracts exceeding \$100,000)

The bidder certifies that:

(a) Any facility to be used in the performance of this contract is, is not listed on the Environmental Protection Agency List of Violating Facilities;

(b) The bidder will immediately notify the PHA/IHA Contracting Officer, before award, of the receipt of any communication from the Administrator, or a designee, of the Environmental Protection Agency, indicating that any facility that the bidder proposes to use for the performance of the contract is under consideration to be listed on the EPA List of Violating Facilities; and

(c) The bidder will include a certification substantially the same as this certification, including this paragraph (c), in every nonexempt subcontract.

13. Bidder's Signature

The bidder hereby certifies that the information contained in these certifications and representations is accurate, complete, and current.

(Signature and Date)

(Typed or Printed Name)

(Title)

(Company Name)

END OF HUD FORM 5369-A (11/92)

STATEMENT OF BIDDER'S QUALIFICATIONS

All questions must be answered and the data provided must be clear and comprehensive. This statement must be notarized. If necessary add separate sheets for items requiring additional explanations. This information must be submitted in a separate sealed envelope marked "Bidder's Qualifications" and inserted inside the sealed Bid envelope. In the event your bid is not selected for award, this envelope will be returned to the Bidder unopened.

SECTION 1: General Information

1. Name of Bidder.
2. Permanent main office address.
3. Date Organized.
4. State in which Bidder is incorporated.
5. Submit your license # for the Contractor's licensing that conforms to the Bid requirements.
6. Number of years you have been engaged in the contracting business under your present firm name.

SECTION 2: Contracting Experience and Past Performance

7. Describe the general character of work normally performed by your company. *Do not exceed one (1) page.*
8. Provide a schedule of all current contracts,

For each contract provide the following:

- a. Contract title.
- b. A general description of the work.
- c. Owner.
- d. Name of Owner's representative, title, address and phone number.
- e. Contract amount.
- f. Contractual start and completion date
- g. The approximate % and dollar amount of work completed.
- h. % of work self performed
- i. Identify any Owner MBE and/or Section 3 contractual goals
- j. % of work and dollar value performed by MBE and/or Section 3 Contractors

9. Describe any past experience your firm may have had of a similar nature to this project. (List each project, number of units or square foot demolished, address, contract amount, contract duration, name and contact information of owner or owner's representative.
10. Has your firm ever failed to complete any work awarded to you? If so, provide information regarding for whom, where, and why?
11. Has your firm ever defaulted on a contract? If so, provide information regarding for whom, where, and why?
12. Describe your company's senior management involvement in ensuring customer satisfaction. Describe your firm's plan for ensuring customer satisfaction for this contract. *Do not exceed two (2) pages.*
13. Provide any additional information or statements that you feel will demonstrate your firm's ability to successfully manage this contract and multiple trade Subcontractors. Information and statements will be considered with particular attention paid to demonstrate past experience with regard to mechanical, electrical, and commercial Contracts. *Do not exceed two (2) pages.*

SECTION 3: Quality Control Plan

14. Describe the specific qualifications of each member of your quality control staff. Indicate their levels of authority to redirect or put a stop to work and on what basis. *Do not exceed two (2) pages.*
15. Describe the detailed procedures to be followed by your quality control staff in visiting the sites; documenting the progress and quality of work; directing subcontractors in the correction of deficiencies; and directing work in the event of problems, design changes, change orders, etc. *Do not exceed three (3) pages.*
16. Describe the approach your firm will utilize to inspect work and correct deficiencies prior to Authority staff being informed that the work is ready for inspection. *Do not exceed two (2) pages.*

SECTION 5: Subcontractor and Section 3 Utilization/Management

17. Provide a description of the provisions your firm will institute regarding your bonding and insurance requirements, imposed on your Subcontractors, that will enhance the viability of Subcontract opportunities for small, minority and Section 3 Subcontractors and make such requirements more attainable for said Subcontractors. *Do not exceed one (1) page.*

18. Describe your firm’s policy of making progress payments to small, minority and Section 3 Subcontractors that will enhance the viability of Subcontract opportunities with your firm and allow you to maximize your firm’s utilization of such businesses. *Do not exceed one (1) page.*
19. Describe your plan for coordinating and controlling Subcontractors (see previous assumptions in the Statement of Bidder’s qualification section of these Contract Documents). Focus specifically on your plan to ensure that subcontractors show up on the job site every day they are scheduled, with appropriate staff and materials, and make reasonable progress. The Authority is particularly interested in a plan that demonstrates capabilities to accomplish the majority of the supervision and management tasks early each workday to minimize elapsed unproductive time. *Do not exceed two (2) pages.*
20. Authority is interested in the Bidder demonstrating past experience in subcontracting to and managing a significant number of trade Contractors. Provide a representative list of Subcontractors you intend to use or solicit bids from during the duration of this contract. For each Subcontractor, list the city and state of its office location. Authority recommends that to demonstrate adequate capability, at a minimum, identify one contractor for each trade area listed below or note your intent to self-perform in that specific trade area. In addition, Authority will give significant attention as to whether or not those listed are local (Tampa metro area) subcontractors, MBE or Section 3 Contractors and if the Bidder has demonstrated experience and/or knowledge of the local and MBE subcontractor market.
- a. Trade Areas: Demolition, earthwork, carpentry, concrete, masonry, roofing, painting, flooring, drywall finishing, mechanical/plumbing, electrical, lead paint abatement, and asbestos abatement, final cleaning, hauling, and principal material suppliers.
 - b. For each trade firm listed in (a) above indicate the most recent project you have worked together on, and provide the approximate dates.
 - c. Provide the information in a table format, similar to the example below:

<u>Trade</u>	<u>Sub Name</u>	<u># of Times</u>					<u>Most Recent</u>
		<u>Used</u>	<u>MBE</u>	<u>Section 3</u>	<u>Local</u>		
<u>Project/Date</u>							
Demolition	ACME Wrecking	6	X	N/A	Yes	NBH 1999	
21. Provide a description of your plan to market subcontract opportunities to the MBE subcontractor community and to market employment opportunities to Section 3 Employees (see Supplemental General Conditions section of these Contract Documents for definition of MBE Contractors, and Section 3 Employees). Provide a summary of any past successes Subcontracting to MBE Subcontractors and hiring Section 3 Employees. For each example cited, provide a brief description and an

Owner Contact and phone number so that the Authority may verify the event occurrence and the achievement cited. *Do not exceed three (3) pages.*

22. To demonstrate the ability to meet the requirements of this contract and the service expectations of Authority, the Bidder shall provide audited or CPA prepared (by a CPA not employed by your firm) Financial Statements for the most recently completed fiscal year (**no later than twelve months ago**).

Provide evidence of available credit in sufficient amount to complete the requirements of this Contract (typical form would be a letter from a credit source).

END OF STATEMENT OF BIDDER'S QUALIFICATIONS



NON COLLUSIVE AFFIDAVIT

State of _____)

County of _____)

_____, being first duly sworn,
(Printed Name)

deposes and says,

That he/she is _____
(Owner, Partner, Officer, Representative or Agent)

the party making the foregoing proposal or bid is genuine and not collusive or sham; that the said bidder has not colluded, conspired, connived or agreed, directly or indirectly, with any bidder or person to put in a sham bid or to refrain from bidding, and has not in any manner, directly or indirectly, sought by agreement or collusion, or communication, or conference, with any person, to fix the bid price or any other bidder, to fix any overhead, profit or cost element of said bid price, or that of any other bidder, or to secure any advantage against the Housing Authority of the City of Tampa or any person interested in the proposed contract; and that all statements in said proposal or bid are true.

SIGNATURE _____

TITLE _____

COMPANY NAME _____

Bidder, if the Bidder is an Individual
Partner, if the Bidder is a Partnership
Officer, if the Bidder is a Corporation

Subscribed & sworn to before me

This _____ day of _____, 20____.

My Commission expires _____, 20____.

END OF NON COLLUSIVE AFFIDAVIT



This Page Intentionally Left Blank



Section 3 & MBE Compliance Certification Forms

The certifications herein are to be submitted with the Bid. See Section 00810 – Special Conditions for explanation of Section and MBE Definitions, Policies and Procedures.



Section 3 & MBE Compliance Certification Forms
To Be Submitted For Each New Section 3 Business Subcontract

Housing Authority of the City of Tampa
Section 3 Program

Certification for Business Concerns Seeking Section 3 Preference

Name of Business: _____

Address of Business: _____

Type of Section 3 Business:

- Corporation
- Partnership
- Sole Proprietorship
- Joint Venture

Name and Address of Section 3 Resident(s) in 51% Ownership Position:

Attached is the following documentation as evidence of Section 3 status (as appropriate):

For person claiming status as a Section 3 Resident:

- Copy of resident lease with Housing Authority of the City of Tampa
- Copy of receipt of public assistance
- Evidence of participation in public assistance program
- Other evidence, as appropriate

For the Section 3 Business entity as applicable:

- Copy of resident lease with Housing Authority of the City of Tampa
- Assumed business name certificate
- List of Owners/stockholders and % ownership of each
- Organizational chart w/names, titles & functional statement
- Certificate of good standing
- Partnership agreement
- Corporation annual report
- Latest board minutes appointing officers
- Additional documentation

Attested by: _____

CORPORATE SEAL

Signature: _____

Date: _____

HOUSING AUTHORITY OF THE CITY OF TAMPA



SECTION 3 PROGRAM

Contractor Certification of Efforts to Fully Comply with Employment and Training Provisions of Section 3 (P&D99-52)

The bidder represents and certifies as part of its bid/offer that it:

- Is a Section 3 Business concern.**
A Section 3 Business concern means a business concern:
 1. That is 51% or more owned by Section 3 Resident(s); or
 2. Whose permanent, full-time employees include persons, at least 30% of whom are currently Section 3 residents, or within the last three years of the date of first employment with the business concern were Section 3 residents; or
 3. That provides evidence of a commitment to subcontract in excess of 25% of the dollar value of all subcontracts to be awarded to business concerns that meet the qualifications set forth in paragraphs 1 or 2 herein.

Is Not a Section 3 Business concern but who has and will continue to seek compliance with Section 3 by certifying to the following efforts as being undertaken.

EFFORTS TO AWARD SUBCONTRACTOR TO SECTION 3 CONCERNS:

(Check ALL that apply)

-
- By contacting business assistance agencies, minority contractors associations and community organizations to inform them of the contracting opportunities and requesting their assistance in identifying Section 3 businesses which may solicit bids for a portion of the work
- By advertising contracting opportunities by posting notices, which provide general information about the work to be contracted and where to obtain additional information, in the common areas of the applicable development(s) owned and managed by the Housing Authority
- By providing written notice to all known Section 3 business concerns of contracting opportunities. This notice should be in sufficient time to allow the Section 3 business concerns to respond to bid invitations
- By following up with Section 3 business concerns that have expressed interest in the contracting opportunities

By coordinating meetings at which Section 3 business concerns could be informed of specific elements of the work for which subcontract bids are being sought

By conducting workshops on contracting procedures and specific contracting opportunities in a timely manner so that Section 3 business concerns can take advantage of contracting opportunities

By advising Section 3 business concerns as to where they may seek assistance to overcome barriers such as inability to obtain bonding, lines of credit, financing, or insurance, and aiding Section 3 businesses in qualifying for such bonding, financing, insurance, etc.

Where appropriate, by breaking out contract work into economically feasible units to facilitate participation by Section 3 businesses

By developing and utilizing a list of eligible Section 3 business concerns

By actively supporting and undertaking joint ventures with Section 3 businesses

EFFORTS TO PROVIDE TRAINING AND EMPLOYMENT TO SECTION 3 RESIDENTS:

(Check ALL that apply)

By entering into a "first source" hiring agreements with organizations representing Section 3 residents

By establishing training programs, which are consistent with the requirements of the Department of Labor, specifically for Section 3 residents in the building trades

By advertising employment and training positions to dwelling units occupied by Category 1 and 2 residents

By contacting resident councils and other resident organizations in the affected housing development to request assistance in notifying residents of the training and employment positions to be filled

By arranging interviews and conducting interviews on the job site

By undertaking such continued job-training efforts as may be necessary to ensure the continued employment of Section 3 residents previously hired for employment opportunities

Authorized Signature of the Bidder & Date

**SELECTION 3 AND MBE
PRE-AWARD COMPLIANCE CERTIFICATION**



Section 3 & MBE Compliance Certification Forms

1. Contractor Name & Address (street, city, zip):	2. Contract Number and Description	3. Dollar Amount of Contract
	4. Contact Person:	5. Phone Number:
	6. Contracting Period:	7. Date Report Submitted:

Part I: Employment and Training of Section 3 Residents (If Prime Contractor is Section 3 Owned Check Here)

The employment and training component of Section 3 applies to the prime contractor and all sub-contractors providing construction services and professional services to the Tampa Housing Authority. It is the responsibility of the Prime Contractor to enforce these same requirements within any sub-contracts.

Instructions: Complete items A, B and C and adjoining worksheet

- A. Total Number of Current Employees? _____
- B. Total Number of Anticipated New Hires and Trainees. _____
- C. Total Number of Section 3 New Hires & Trainees?
(the established goal is 30% of Line B) _____

Adjoining Worksheet		
(A) Job Category	(B) Number of Anticipated New Hires and Trainees	(C) Number of column (B) that will be Section 3 Residents
Professional		
Technical		
Construction by Trade(list)		
Other (list)		
Total		

Part II: Subcontract awards – Section 3 and MBE (If Prime Contractor is Section 3 Owned Check Here)

The contracting component of Section 3 and minority-owned business participation apply to all prime contractors and sub-contractors providing construction services, professional services and supplies to the Tampa Housing Authority's project. It is the responsibility of the prime contractor to enforce the same requirements within any sub-contracts.

Instructions: All contractors must complete item D. Complete item E for construction contracts only. Complete item F for professional service and supplier contracts only. All contractors must complete item G.

D. Total dollar amount of all sub-contracts anticipated for this project? \$ _____

Applies to construction contracts only:

E. Total amount of anticipated Section 3 sub-contract awards? \$ _____
(The established goal is 10% of Line D)

Applies to professional service contracts and suppliers:

F. Total amount of anticipated Section 3 sub-contract awards? \$ _____
(The established goal is 3% of Line D)

Applies to all contracts:

G. Total amount of anticipated minority-owned business contract awards? \$ _____

(The established goal is 20% of Line D) A minority-owned business is an entity that is 51% or more owned and controlled by one or more of the following minority group members: Black Americans, Hispanic Americans, Native Americans, Asian Pacific Americans, Asian Indian Americans and Hasidic Jewish Americans.

Part III – Certification

As a duly authorize representative of the prime contractor, it is hereby agreed that the prime contractor and all sub-contractors will make every effort to achieve at least the minimum levels for compliance with Section 3 and Minority- Owned Business participation goals. It is further understood that the undersigned will enforce and ensure compliance within all subcontracts.

Signature:	Print Name and Title	Date
------------	----------------------	------



HOUSING AUTHORITY OF THE CITY OF TAMPA
SECTION 3 CONTRACTORS LIST
Updated May 30, 2018

Company Name	Services Provided	Contact Name	Company Address	Contact Phone	Email
3-Vets, Inc.	Construction Painting, installation of windows and doors, construction / contract administration	Reggie Tim	1907 E. Hillsborough Ave., Suite 101 Tampa, FL 33610	813-237-8387 / 813-232-3894(fax)	vetinds@aol.com
AIRMAX1, Inc.	A/C Service and Repairs	Eloy Rojas	PO Box 263394 Tampa, FL 33685	813-385-1867	Airmax1ac@yahoo.com
Amack's Cleaning Service	General cleaning services	Alexis Mack	10422 Avelar Ridge Drive, Riverview, FL 33578	813-390-0644	lexmack63@gmail.com
American Ecosystems, Inc.	Aquatic Mgmt., Water Treatment, Other	Kevin Youngberg	10460 75 th Street Largo, FL 33777	727-545-4404	kry@american-ecosystems.com
Arcor Trading, Inc.	Painting, waterproofing	Juan Restrepo / Luis Arguello	P.O. Box 4149, Tampa, FL 33677	813-446-3225	luisgamin55@gmail.com
Atlas Eco Pest Control Lawn and Termite	Construction cleaning, Pest control, termite treatment, Janitorial, Landscape/Lawn Maintenance	Eddie Melcon	3308 N. Florida Ave. Tampa, FL 33603	813-843-6342	ed@atlaseco-info.com

**The Tampa Housing Authority's Certified Section 3 Contractor list is included for information only and does not reflect all possible certified Section 3 businesses. There may be other agencies that maintain Section 3 contractor listings that bidders and proposers may also consider.*



HOUSING AUTHORITY OF THE CITY OF TAMPA
SECTION 3 CONTRACTORS LIST

Updated May 30, 2018

BJ Construction II, Inc.	General Construction	Ron Richardson	235 W. Brandon Blvd., Unit 182, Brandon, FL 33511	813-347-3028	Rrich13@bjconstruction2.com
BJ Enterprise II, Inc.	Real Estate, marketing, print shop and internet services	Ron Richardson	235 W. Brandon Blvd., Unit 182, Brandon, FL 33511	813-347-3028	Rrich13@bjconstruction2.com
Cablelytics LLC	Communications, Cable	Floyd Freeman	4607 Limerick Drive Tampa, FL 33610	813-727-6728	Ffreeman@cablelytics.com
Campellos Houses Solutions	Cabinets	Jose Campello	2010 Clarice Circle Tampa, FL 33619	813-650-6714	Yeidavid1106@gmail.com
Classic Construction Ltd. Co.	GC, Construction	Brian Lodermeier	16674 Collections Center Drive	727-421-2845	classicltd@gmail.com
Classie Ladies' Cleaning Service	General cleaning services	Classie McMillen	P.O. Box 16924, Tampa, FL 33687	813-856-8092	ClassieLadie35@gmail.com

**The Tampa Housing Authority's Certified Section 3 Contractor list is included for information only and does not reflect all possible certified Section 3 businesses. There may be other agencies that maintain Section 3 contractor listings that bidders and proposers may also consider.*



HOUSING AUTHORITY OF THE CITY OF TAMPA
SECTION 3 CONTRACTORS LIST

Updated May 30, 2018

Climatize Air of Florida	A/C Service/Repairs, HVAC, Refrigeration	Marcus Carn	7610 Dragon Fly Loop Gibsonton, FL 33534	813-638-5434	climatizeairmkt@gmail.com
D & R United Cleaning Services, Corp.	New Construction, Commercial and Residential cleaning	Diana Rebaza	1611 Prowmore Drive, Brandon, FL 33511	407-435-7032	drunitedcleaning@hotmail.com ; rebazadiana2007@hotmail.com
Darryl Ward's Painting	Construction Painting	Darryl Ward	27232 Big Sur Drive, Wesley Chapel, FL 33544	813-918-3806	dwmonavie@gmail.com
Faithful Cleaning Service To The Rescue	Commercial and Residential cleaning services	Michelle Henry	11307 N. 50th Street, Tampa, FL 33617	813-210-3616	faithfulcleaningservice17@yahoo.com
Full of Hope Cleaning Services	Construction and Janitorial Cleaning	Hope Terrible	6913 Bon Air Dr., Apt. C Tampa, FL 33617	813-992-5382	hterrible@yahoo.com
Graphix T's, Inc.	Screen Printing, Banners	Randy Johnson	10071 Country Road WeekiWachee, FL 34613	352-600-9170	Rmj45@gpxts.com

**The Tampa Housing Authority's Certified Section 3 Contractor list is included for information only and does not reflect all possible certified Section 3 businesses. There may be other agencies that maintain Section 3 contractor listings that bidders and proposers may also consider.*



HOUSING AUTHORITY OF THE CITY OF TAMPA
SECTION 3 CONTRACTORS LIST

Updated May 30, 2018

I. B. B., Inc.	install privacy walls, retaining walls, buffer walls, sound walls, security walls, animal containment walls, enclosures, fencing, etc.	Donald Burkett	2804 Lutz Lake Fern Rd., Tampa, FL 33558	813-949-4786	donb@burint.com
Impact Construction Services Div. 1	GC/Construction	Alex Maldonado	4628 Fremont Ter S St. Petersburg, FL 33711	708-214-9599	Alex.m@icsdi.com
Intex Builders	GC/Construction, Home Improvement, Roofing, Fire Sprinkler, Drywall, Professional Painting, Carpet Installation, Flooring Installation, Contractor Doors, Countertops, Asphalt services, Fencing, Cabinets, Playground recreational equipment	David Knight	3800 Gunn Hwy Tampa, FL 33618	813-205-1892	david@intexbuilders.net

**The Tampa Housing Authority's Certified Section 3 Contractor list is included for information only and does not reflect all possible certified Section 3 businesses. There may be other agencies that maintain Section 3 contractor listings that bidders and proposers may also consider.*



HOUSING AUTHORITY OF THE CITY OF TAMPA
SECTION 3 CONTRACTORS LIST
Updated May 30, 2018

Johnson & Johnson Janitorial	Janitorial Cleaning, Construction Cleaning, Environmental Services	Janice and Earl Johnson	7901 Bahia Ave., Tampa, FL 33619	813-629-6565 / 813-677-7317	Janice.johnson33@verizon.net
Johnson Hauling	Stucco, Drywall, Professional Painting, Demolition Hauling, Emergency Clean-up/Demo, Asphalt Services, Landscape lawn maintenance, Tree service, Debris removal	Eugene Johnson	709 E. Lake Ave., Tampa, FL 33603	813-417-9116	johnsonhauling78@gmail.com
Kenstruction Dynamics, Inc.	GC/ Construction	Rozelia Kennedy	1210 Millennium Parkway Suite 1047 Brandon, FL 33511	813-643-4449	Rozelia.kennedy@kenstruction.net
KSJ Consulting, Inc.	Clinician	Karen StJean	5107 29 th Ave. South Gulfport, FL 33707	727-224-3553	karen@nehemiahsvillage.org
KT Klean LLC	Janitorial Services, Carpet/Upholstery cleaning	Keenan Dixon	5024 S. 87 th Street Tampa, FL 33619	813-394-0439	Ktklean624@gmail.com
NuTech Roofing & Construction	Licensed Roofing Contractor, Licensed GC	Ramiro Rubio	11806 Baytree Drive, Riverview, FL 33569	813-787-9800	rrubio.group@gmail.com

**The Tampa Housing Authority's Certified Section 3 Contractor list is included for information only and does not reflect all possible certified Section 3 businesses. There may be other agencies that maintain Section 3 contractor listings that bidders and proposers may also consider.*



HOUSING AUTHORITY OF THE CITY OF TAMPA
SECTION 3 CONTRACTORS LIST

Updated May 30, 2018

On-Line Electrician LLC	Electrician	Tyler Luper	210 W. Powhatan Tampa, FL 33604	813-335-8263	On_line_ele@live.com
Paramount Trim, Inc.	Carpentry, Contractor-Doors	Walid Ben Khaffed	7419 Savannah Lane Tampa, FL 33637	813-927-1082	paramountrim@yahoo.com
Pastels Child Development Center	Childcare	Spencena Dalmas	PO Box 286 Lakeland, FL 33802	813-900-8176	pastelschilddevelopment@gmail.com
Pick N Go Property Waste Services	Waste Clean-up	Joe Biccum	13575 58 th Street N #173 Clearwater, FL 33760	727-504-4672	joeb@pickngowaste.com
Pipeline Construction, LLC	Site preparation and underground utilities	Christopher Lee	1313 33rd Avenue, Tampa, FL 33603	813-927-6646	pipelinecontractingLLC@yahoo.com
Randall Mechanical, Inc.	Plumbing Services	Paul Welsh	3102 Cherry Palm Drive Suite 150 Tampa, FL 33619	813-626-6161	pwelsh@ramdallmechanical.com
Ruedas Remodeling, LLC	Drywall	Glen Rueda	1030 Brass Ln. Holiday, FL 34691	813-526-9695	ruedasremodeling@yahoo.com

**The Tampa Housing Authority's Certified Section 3 Contractor list is included for information only and does not reflect all possible certified Section 3 businesses. There may be other agencies that maintain Section 3 contractor listings that bidders and proposers may also consider.*



HOUSING AUTHORITY OF THE CITY OF TAMPA
SECTION 3 CONTRACTORS LIST

Updated May 30, 2018

Ryman Commercial Roofing, Inc.	AC Service/Repairs, AC Supplies	Christian	36413 SR54 Zephyrhills, FL 33541	813-526-9695	christian@rymanroofing.com
Southwest Structural Systems	Other	George LeBlanc	5774 Corporation Circle Ft. Myers, FL 33905	813-703-4792	glablance@yahoo.com
Special "K" Cleaning and Service Co.	Janitorial Cleaning and Window Cleaning	Lear Johnson Lockley	1112 Union Street, Tampa, FL 33607	813-258-9593	
Spotless Cleaning 7, LLC	Janitorial Services, Pressure Washer, Hauling	Tow and Reid	PO Box 11093 Tampa, FL 33680	813-370-3645	Spotlesscleaning40@yahoo.com
Sunbelt Constructing Company LLC	Flooring	Mark Stalsitz	3109 Reseda Court, Tampa, FL 33618	813-312-4460	sunbelt.mark@gmail.com
SunScape Grounds Maintenance	Landscape and Lawn Maintenance	Demond Bryant	3624 18th Street N. Tampa, FL 33603	813-376-8755 / 813-247-3100	sunscapegmi@verizon.net

**The Tampa Housing Authority's Certified Section 3 Contractor list is included for information only and does not reflect all possible certified Section 3 businesses. There may be other agencies that maintain Section 3 contractor listings that bidders and proposers may also consider.*



**HOUSING AUTHORITY OF THE CITY OF TAMPA
SECTION 3 CONTRACTORS LIST**

Updated May 30, 2018

Universal Contracting Services, Inc.	Drywall, Professional painting, Carpentry, Pressure washer	Hadeel Elshehaiy	11311 Hollyglen Drive Tampa, FL 33624	813-966-1508	ucs@email.com
Women of Love Through Faith Cleaning Service	Janitorial Services	Ruby Scott	12737 N 19 th Street #7 Tampa, FL 33612	812405-9690	womenoflovethroughfaith@gmail.com
Z's Fine Furniture, Inc.	Kitchen and bathroom cabinets install and refacing, furniture	Gina and Michael Zayas	4401 W. Jean Street, Tampa, FL 33614	813-323-3893 / 813-309-2339	mikezcabinets@gmail.com

**For Questions Regarding Section 3, please contact
Gwen Bedwell, Administrative Assistant, Housing Authority of the City of
Tampa Office of Real Estate Development, 5301 W Cypress Street, Tampa,
Florida 33607 813-341-9101 ext. 2630 or e-mail at gwen.bedwell@thaf1.com**

A searchable list of local MBE (Minority Business Enterprise) certified businesses can be found at the City of Tampa's website here: <https://tampa.diversitysoftware.com/FrontEnd/VendorSearchPublic.asp?TN=tampa&XID=846>
or at the Hillsborough County website here:
<https://hillsboroughcounty.diversitycompliance.com/FrontEnd/SEARCHCERTIFIEDDIRECTORY.asp>

**The Tampa Housing Authority's Certified Section 3 Contractor list is included for information only and does not reflect all possible certified Section 3 businesses. There may be other agencies that maintain Section 3 contractor listings that bidders and proposers may also consider.*



**SWORN STATEMENT UNDER SECTION 287.133(3)(A), FLORIDA
STATUTES, ON PUBLIC ENTITY CRIMES**

(To be signed in the presence of notary public or other officer authorized to administer oaths.)

Before me, the undersigned authority, personally appeared _____
who, being by me first duly sworn, made the following statement:

1. The business address of
(name of Offeror or business) is.
2. My relationship to _____ (name of Offeror or business) is
_____. (Relationship such as sole proprietor, partner, president,
vice president).
3. I understand that a public entity crime as defined in Section 287.133 of the Florida Statutes includes a violation of any state or federal law by a person with respect to and directly related to the transaction of business with any public entity in Florida or with an agency or political subdivision of any other state or with the United States, including, but not limited to, any proposal or contract for goods or services to be provided to any public entity or such an agency or political subdivision and involving antitrust, fraud, theft, bribery, collusion, racketeering, conspiracy or material misrepresentation.
4. I understand that "convicted" or "conviction" is defined by the Florida Statutes to mean a finding of guilt or a conviction of a public entity crime, with or without an adjudication of guilt, in any federal or state trial court of record relating to charges brought by indictment or information after July 1, 1989, as a result of a jury verdict, non-jury trial, or entry of a plea of guilt or no contest.
5. I understand that "affiliate" is defined by the Florida Statutes to mean (1) a predecessor or successor of a person or a corporation convicted of a public entity crime, or (2) an entity under the control of any natural person who is active in the management of the entity and who has been convicted of a public entity crime, or (3) those officers, directors, executives, partners, shareholders, employees, members, and agents who are active in the management of an affiliate, or (4) a person or corporation who knowingly entered into a joint venture with a person who has been convicted of a public entity crime in Florida during the preceding 36 months.
6. Neither the Offeror or contractor, nor any officer, director, executive, partner, shareholder, employee, member or agent who is active in the management of the Offeror or contractor, nor any affiliate of the Offeror or contractor has been convicted of a public entity crime subsequent to July 1, 1989. (Draw a line through paragraph 6 if paragraph 7 below applies.)



7. There has been a conviction of a public entity crime by the Offeror or contractor, or an officer, director, executive, partner, shareholder, employee, member or agent of the Offeror or contractor who is active in the management of the Offeror or contractor or an affiliate of the Offeror or contractor. A determination has been made pursuant to Section 287.133(3) by order of the Division of Administrative Hearings that it is not in the public interest for the name of the convicted person or affiliate to appear on the convicted vendor list. The name of the convicted person or affiliate is _____ a copy of the order of the Division of Administrative Hearings is attached to this statement. (Draw a line through paragraph 7 if paragraph 6 above applies.)

(Signature)

(Print name)

STATE OF
COUNTY OF

The foregoing instrument was acknowledged before me this _____ day of _____ by _____, who is personally known to me or who has produced _____ as identification and who did take an oath.

_____ Notary Public

My Commission Expires: _____



PERFORMANCE BOND FORM

KNOW ALL MEN BY THESE PRESENTS:

That

As Principal, and _____

a corporation of the State of _____, as

Surety, are held and firmly bound unto the HOUSING AUTHORITY OF THE CITY OF TAMPA,

as Obligee, in the amount of _____ DOLLARS

(\$ _____) for the payment thereof Principal and Surety bond themselves, their

heirs, executors, administrators, successors and assigns, jointly and severally, firmly by these present.

WHEREAS, Principal has, by written agreement dated _____, 20____,

entered into a contract with Obligee or _____

in accordance with Contract Documents prepared by THE HOUSING AUTHORITY OF THE CITY OF TAMPA, which Contract is, by reference, made a part hereof and is hereinafter referred to as the Contract.

NOW, THEREFORE, the conditions of this obligation are such that if the Principal shall faithfully satisfy all claims and demands incurred by the Principal of said Contract, and shall pay all obligation arising there under, and shall fully indemnify and save harmless the OWNER from all cost and damage which the OWNER might suffer by reason of the failure of the Principal to do so, and shall fully reimburse and repay to the OWNER all costs, damages, and expenses which the OWNER may incur, making good any default by the Principal, and shall promptly make payment to all persons supplying labor, equipment, or materials for use in the prosecution of the Work, whether by subcontractor or otherwise, and including all insurance premiums on said Work as provided for in such Contract, then this obligation shall be null and void; otherwise, it shall remain in full force and effect.

In addition, the Principal and Surety, jointly and severally, expressly guarantee that the Owner will be held harmless from any liens, claims, demands, or obligations in conjunction with materials or services provided with respect to this Contract. This Bond shall remain in effect for a period of one year from the date of final acceptance.



The OWNER may sue on this Bond, and any person furnishing material or performing labor, either as an individual or as a subcontractor, shall have the right to sue on this bond, in the name of the OWNER, for his/her use and benefit.

ATTEST

Contractor

Secretary

BY: _____
Title

Surety

(SEAL)

BY: _____

Signed and sealed this _____ day of _____, 20__.



PAYMENT BOND FORM

THIS INSTRUMENT WITNESSETH: That we (1)

a(2) _____

organized under the law's of the State of _____ hereinafter authorized to do business in the State of (3) _____, and (4) _____ as Surety

are held and firmly bound unto HOUSING AUTHORITY OF THE CITY OF TAMPA, hereinafter called the OWNER, in accordance with a referred to, in the penal sum of

(5) _____ Dollars (\$ _____) lawful money of the United States, well and truly to be paid unto the said OWNER, for the payment of which we bind ourselves, our heirs, executors, administrators, successors and assignees, jointly and severally firmly by these presents.

WHEREAS, the said Principal has entered into a written contract with the OWNER, dated, _____ 20_____ for work designated as

Located in _____, in conformity with Contract Documents hereby referred to and made a part hereof, the same, to all intents and purposes, as if written at length herein, in which Contract the said Principal has contracted to perform the Work specified in said Contract in accordance with the terms thereof.

- (1) Contractor
- (2) Corporation. Partnership or Individual
- (3) State in which project is located
- (4) Surety
- (5) 100 percent of the Contract

NOW THEREFORE, the conditions of this obligation are such that if the Principal shall faithfully satisfy all claims and demands incurred by the Principal of said Contract, and shall pay all

FY2014/2015



obligations arising there-under, and shall fully indemnify and save harmless the OWNER from all cost and damage which the OWNER might suffer by reason of the failure of the Principal to do so, and shall fully reimburse and repay to the OWNER all costs, damages, and expenses which the OWNER may incur, making good any default

by the Principal, and shall promptly make payment to all persons supplying labor, equipment or materials for use in the prosecution of the Work, whether by subcontractor or otherwise, and including all insurance premiums on said Work as provided for in such Contract, then this obligation shall be null and void; otherwise, it shall remain in full force and effect.

In addition, the Principal and Surety, jointly and severally, expressly guarantee that the Owner will be held harmless from any liens, claims, demands or obligations in conjunction with materials or services provided with respect to this Contract. The bond shall remain in effect for a period of one year from the date of final acceptance.

The OWNER may sue on this Bond, and any person furnishing material or performing labor, either as an individual or as a subcontractor, shall have the right to sue on this bond, in the name of the OWNER, for his/her use and benefit. The said Surety, for value received, hereby stipulates and agrees that no change, extension of time, alteration or addition to the terms of the Contract, or to the Work to be performed there-under, or the Contract Documents accompanying the same, shall in any way affect its obligation on this Bond, and it does hereby waive notice of any such changes, extension of time, alteration or addition to the terms of the Contract or to the Work or to the Contract Documents.

PROVIDED, FURTHER, that no final settlement between the OWNER and the CONTRACTOR shall abridge the right of any beneficiary herein under, whose claim may be unsatisfied.

IN WITNESS WHEREOF, this instrument is executed in several counterparts, each one of which shall be deemed an original, this the _____ day of _____, 20_____.

(Seal)
Attest:

Contractor:
BY: _____
TITLE: _____

(Seal)
Attest:

Surety:
BY: _____
Attorney-in-Fact

General Conditions for Construction Contracts - Public Housing Programs

U.S. Department of Housing and Urban Development
Office of Public and Indian Housing
OMB Approval No. 2577-0157 (exp. 1/31/2017)

Applicability. This form is applicable to any construction/development contract greater than \$100,000.

This form includes those clauses required by OMB's common rule on grantee procurement, implemented at HUD in 24 CFR 85.36, and those requirements set forth in Section 3 of the Housing and Urban Development Act of 1968 and its amendment by the Housing and Community Development Act of 1992, implemented by HUD at 24 CFR Part 135. The form is required for construction contracts awarded by Public Housing Agencies (PHAs).

The form is used by Housing Authorities in solicitations to provide necessary contract clauses. If the form were not used, HAs would be unable to enforce their contracts.

Public reporting burden for this collection of information is estimated to average 1.0 hours per response, including the time for reviewing instructions, searching existing data sources, gathering and maintaining the data needed, and completing and reviewing the collection of information. Responses to the collection of information are required to obtain a benefit or to retain a benefit.

The information requested does not lend itself to confidentiality.

HUD may not conduct or sponsor, and a person is not required to respond to a collection of information unless it displays a currently valid OMB number.

Clause		Page	Clause		Page
1.	Definitions	2	Administrative Requirements		
2.	Contractor's Responsibility for Work	2	25.	Contract Period	9
3.	Architect's Duties, Responsibilities and Authority	2	26.	Order of Precedence	9
4.	Other Contracts	3	27.	Payments	9
Construction Requirements			28.	Contract Modifications	10
5.	Preconstruction Conference and Notice to Proceed	3	29.	Changes	10
6.	Construction Progress Schedule	3	30.	Suspension of Work	11
7.	Site Investigation and Conditions Affecting the Work	3	31.	Disputes	11
8.	Differing Site Conditions	4	32.	Default	11
9.	Specifications and Drawings for Construction	4	33.	Liquidated	12
10.	As-Built Drawings	5	34.	Termination of Convenience	12
11.	Material and Workmanship	5	35.	Assignment of Contract	12
12.	Permits and Codes	5	36.	Insurance	12
13.	Health, Safety, and Accident Prevention	6	37.	Subcontracts	13
14.	Temporary Buildings and Transportation Materials	6	38.	Subcontracting with Small and Minority Firms, Women's Business Enterprise, and Labor Surplus Area Firms	13
15.	Availability and Use of Utility Services	6	39.	Equal Employment Opportunity	13
16.	Protection of Existing Vegetation, Structures, Equipment, Utilities, and Improvements	6	40.	Employment, Training, and Contracting Opportunities for Low-Income Persons, Section 3 of the Housing and Urban Development Act of 1968	14
17.	Temporary Buildings and Transportation Materials	7	41.	Interest of Members of Congress	15
18.	Clean Air and Water	7	42.	Interest of Members, Officers, or Employees and Former Members, Officers, or Employees	15
19.	Energy Efficiency	7	43.	Limitations on Payments Made to Influence	15
20.	Inspection and Acceptance of Construction	7	44.	Royalties and Patents	15
21.	Use and Possession Prior to Completion	8	45.	Examination and Retention of Contractor's Records	15
22.	Warranty of Title	8	46.	Labor Standards-Davis-Bacon and Related Acts	15
23.	Warranty of Construction	8	47.	Non-Federal Prevailing Wage Rates	19
24.	Prohibition Against Liens	9	48.	Procurement of Recovered Materials	19

1. Definitions

- (a) "Architect" means the person or other entity engaged by the PHA to perform architectural, engineering, design, and other services related to the work as provided for in the contract. When a PHA uses an engineer to act in this capacity, the terms "architect" and "engineer" shall be synonymous. The Architect shall serve as a technical representative of the Contracting Officer. The Architect's authority is as set forth elsewhere in this contract.
 - (b) "Contract" means the contract entered into between the PHA and the Contractor. It includes the forms of Bid, the Bid Bond, the Performance and Payment Bond or Bonds or other assurance of completion, the Certifications, Representations, and Other Statements of Bidders (form HUD-5370), these General Conditions of the Contract for Construction (form HUD-5370), the applicable wage rate determinations from the U.S. Department of Labor, any special conditions included elsewhere in the contract, the specifications, and drawings. It includes all formal changes to any of those documents by addendum, change order, or other modification.
 - (c) "Contracting Officer" means the person delegated the authority by the PHA to enter into, administer, and/or terminate this contract and designated as such in writing to the Contractor. The term includes any successor Contracting Officer and any duly authorized representative of the Contracting Officer also designated in writing. The Contracting Officer shall be deemed the authorized agent of the PHA in all dealings with the Contractor.
 - (d) "Contractor" means the person or other entity entering into the contract with the PHA to perform all of the work required under the contract.
 - (e) "Drawings" means the drawings enumerated in the schedule of drawings contained in the Specifications and as described in the contract clause entitled Specifications and Drawings for Construction herein.
 - (f) "HUD" means the United States of America acting through the Department of Housing and Urban Development including the Secretary, or any other person designated to act on its behalf. HUD has agreed, subject to the provisions of an Annual Contributions Contract (ACC), to provide financial assistance to the PHA, which includes assistance in financing the work to be performed under this contract. As defined elsewhere in these General Conditions or the contract documents, the determination of HUD may be required to authorize changes in the work or for release of funds to the PHA for payment to the Contractor. Notwithstanding HUD's role, nothing in this contract shall be construed to create any contractual relationship between the Contractor and HUD.
 - (g) "Project" means the entire project, whether construction or rehabilitation, the work for which is provided for in whole or in part under this contract.
 - (h) "PHA" means the Public Housing Agency organized under applicable state laws which is a party to this contract.
 - (j) "Specifications" means the written description of the technical requirements for construction and includes the criteria and tests for determining whether the requirements are met.
 - (l) "Work" means materials, workmanship, and manufacture and fabrication of components.
- (a) The Contractor shall furnish all necessary labor, materials, tools, equipment, and transportation necessary for performance of the work. The Contractor shall also furnish all necessary water, heat, light, and power not made available to the Contractor by the PHA pursuant to the clause entitled Availability and Use of Utility Services herein.
 - (b) The Contractor shall perform on the site, and with its own organization, work equivalent to at least [12] (12 percent unless otherwise indicated) of the total amount of work to be performed under the order. This percentage may be reduced by a supplemental agreement to this order if, during performing the work, the Contractor requests a reduction and the Contracting Officer determines that the reduction would be to the advantage of the PHA.
 - (c) At all times during performance of this contract and until the work is completed and accepted, the Contractor shall directly superintend the work or assign and have on the work site a competent superintendent who is satisfactory to the Contracting Officer and has authority to act for the Contractor.
 - (d) The Contractor shall be responsible for all damages to persons or property that occur as a result of the Contractor's fault or negligence, and shall take proper safety and health precautions to protect the work, the workers, the public, and the property of others. The Contractor shall hold and save the PHA, its officers and agents, free and harmless from liability of any nature occasioned by the Contractor's performance. The Contractor shall also be responsible for all materials delivered and work performed until completion and acceptance of the entire work, except for any completed unit of work which may have been accepted under the contract.
 - (e) The Contractor shall lay out the work from base lines and bench marks indicated on the drawings and be responsible for all lines, levels, and measurements of all work executed under the contract. The Contractor shall verify the figures before laying out the work and will be held responsible for any error resulting from its failure to do so.
 - (f) The Contractor shall confine all operations (including storage of materials) on PHA premises to areas authorized or approved by the Contracting Officer.
 - (g) The Contractor shall at all times keep the work area, including storage areas, free from accumulations of waste materials. After completing the work and before final inspection, the Contractor shall (1) remove from the premises all scaffolding, equipment, tools, and materials (including rejected materials) that are not the property of the PHA and all rubbish caused by its work; (2) leave the work area in a clean, neat, and orderly condition satisfactory to the Contracting Officer; (3) perform all specified tests; and, (4) deliver the installation in complete and operating condition.
 - (h) The Contractor's responsibility will terminate when all work has been completed, the final inspection made, and the work accepted by the Contracting Officer. The Contractor will then be released from further obligation except as required by the warranties specified elsewhere in the contract.

3. Architect's Duties, Responsibilities, and Authority

- (a) The Architect for this contract, and any successor, shall be designated in writing by the Contracting Officer.

2. Contractor's Responsibility for Work

- (b) The Architect shall serve as the Contracting Officer's technical representative with respect to architectural, engineering, and design matters related to the work performed under the contract. The Architect may provide direction on contract performance. Such direction shall be within the scope of the contract and may not be of a nature which: (1) institutes additional work outside the scope of the contract; (2) constitutes a change as defined in the Changes clause herein; (3) causes an increase or decrease in the cost of the contract; (4) alters the Construction Progress Schedule; or (5) changes any of the other express terms or conditions of the contract.
- (c) The Architect's duties and responsibilities may include but shall not be limited to:
- (1) Making periodic visits to the work site, and on the basis of his/her on-site inspections, issuing written reports to the PHA which shall include all observed deficiencies. The Architect shall file a copy of the report with the Contractor's designated representative at the site;
 - (2) Making modifications in drawings and technical specifications and assisting the Contracting Officer in the preparation of change orders and other contract modifications for issuance by the Contracting Officer;
 - (3) Reviewing and making recommendations with respect to - (i) the Contractor's construction progress schedules; (ii) the Contractor's shop and detailed drawings; (iii) the machinery, mechanical and other equipment and materials or other articles proposed for use by the Contractor; and, (iv) the Contractor's price breakdown and progress payment estimates; and,
 - (4) Assisting in inspections, signing Certificates of Completion, and making recommendations with respect to acceptance of work completed under the contract.

4. Other Contracts

The PHA may undertake or award other contracts for additional work at or near the site of the work under this contract. The Contractor shall fully cooperate with the other contractors and with PHA employees and shall carefully adapt scheduling and performing the work under this contract to accommodate the additional work, heeding any direction that may be provided by the Contracting Officer. The Contractor shall not commit or permit any act that will interfere with the performance of work by any other contractor or by PHA employees

Construction Requirements

5. Pre-construction Conference and Notice to Proceed

- (a) Within ten calendar days of contract execution, and prior to the commencement of work, the Contractor shall attend a preconstruction conference with representatives of the PHA, its Architect, and other interested parties convened by the PHA. The conference will serve to acquaint the participants with the general plan of the construction operation and all other requirements of the contract. The PHA will provide the Contractor with the date, time, and place of the conference.
- (b) The contractor shall begin work upon receipt of a written Notice to Proceed from the Contracting Officer or designee. The Contractor shall not begin work prior to receiving such notice.

6. Construction Progress Schedule

- (a) The Contractor shall, within five days after the work commences on the contract or another period of time determined by the Contracting Officer, prepare and submit to the Contracting Officer for approval three copies of a practicable schedule showing the order in which the Contractor proposes to perform the work, and the dates on which the Contractor contemplates starting and completing the several salient features of the work (including acquiring labor, materials, and equipment). The schedule shall be in the form of a progress chart of suitable scale to indicate appropriately the percentage of work scheduled for completion by any given date during the period. If the Contractor fails to submit a schedule within the time prescribed, the Contracting Officer may withhold approval of progress payments or take other remedies under the contract until the Contractor submits the required schedule.
- (b) The Contractor shall enter the actual progress on the chart as required by the Contracting Officer, and immediately deliver three copies of the annotated schedule to the Contracting Officer. If the Contracting Officer determines, upon the basis of inspection conducted pursuant to the clause entitled Inspection and Acceptance of Construction, herein that the Contractor is not meeting the approved schedule, the Contractor shall take steps necessary to improve its progress, including those that may be required by the Contracting Officer, without additional cost to the PHA. In this circumstance, the Contracting Officer may require the Contractor to increase the number of shifts, overtime operations, days of work, and/or the amount of construction plant, and to submit for approval any supplementary schedule or schedules in chart form as the Contracting Officer deems necessary to demonstrate how the approved rate of progress will be regained.
- (c) Failure of the Contractor to comply with the requirements of the Contracting Officer under this clause shall be grounds for a determination by the Contracting Officer that the Contractor is not prosecuting the work with sufficient diligence to ensure completion within the time specified in the Contract. Upon making this determination, the Contracting Officer may terminate the Contractor's right to proceed with the work, or any separable part of it, in accordance with the Default clause of this contract.

7. Site Investigation and Conditions Affecting the Work

- (a) The Contractor acknowledges that it has taken steps reasonably necessary to ascertain the nature and location of the work, and that it has investigated and satisfied itself as to the general and local conditions which can affect the work or its cost, including but not limited to, (1) conditions bearing upon transportation, disposal, handling, and storage of materials; (2) the availability of labor, water, electric power, and roads; (3) uncertainties of weather, river stages, tides, or similar physical conditions at the site; (4) the conformation and conditions of the ground; and (5) the character of equipment and facilities needed preliminary to and during work performance. The Contractor also acknowledges that it has satisfied itself as to the character, quality, and quantity of surface and subsurface materials or obstacles to be encountered insofar as this information is

reasonably ascertainable from an inspection of the site, including all exploratory work done by the PHA, as well as from the drawings and specifications made a part of this contract. Any failure of the Contractor to take the actions described and acknowledged in this paragraph will not relieve the Contractor from responsibility for estimating properly the difficulty and cost of successfully performing the work, or for proceeding to successfully perform the work without additional expense to the PHA.

- (b) The PHA assumes no responsibility for any conclusions or interpretations made by the Contractor based on the information made available by the PHA. Nor does the PHA assume responsibility for any understanding reached or representation made concerning conditions which can affect the work by any of its officers or agents before the execution of this contract, unless that understanding or representation is expressly stated in this contract.

8. Differing Site Conditions

- (a) The Contractor shall promptly, and before the conditions are disturbed, give a written notice to the Contracting Officer of (1) subsurface or latent physical conditions at the site which differ materially from those indicated in this contract, or (2) unknown physical conditions at the site(s), of an unusual nature, which differ materially from those ordinarily encountered and generally recognized as inhering in work of the character provided for in the contract.
- (b) The Contracting Officer shall investigate the site conditions promptly after receiving the notice. Work shall not proceed at the affected site, except at the Contractor's risk, until the Contracting Officer has provided written instructions to the Contractor. If the conditions do materially so differ and cause an increase or decrease in the Contractor's cost of, or the time required for, performing any part of the work under this contract, whether or not changed as a result of the conditions, the Contractor shall file a claim in writing to the PHA within ten days after receipt of such instructions and, in any event, before proceeding with the work. An equitable adjustment in the contract price, the delivery schedule, or both shall be made under this clause and the contract modified in writing accordingly.
- (c) No request by the Contractor for an equitable adjustment to the contract under this clause shall be allowed, unless the Contractor has given the written notice required; provided, that the time prescribed in (a) above for giving written notice may be extended by the Contracting Officer.
- (d) No request by the Contractor for an equitable adjustment to the contract for differing site conditions shall be allowed if made after final payment under this contract.

9. Specifications and Drawings for Construction

- (a) The Contractor shall keep on the work site a copy of the drawings and specifications and shall at all times give the Contracting Officer access thereto. Anything mentioned in the specifications and not shown on the drawings, or shown on the drawings and not mentioned in the specifications, shall be of like effect as if shown or mentioned in both. In case of difference between drawings and specifications, the specifications shall govern. In case of discrepancy in the figures, in the drawings, or in the specifications, the matter shall be

promptly submitted to the Contracting Officer, who shall promptly make a determination in writing. Any adjustment by the Contractor without such a determination shall be at its own risk and expense. The Contracting Officer shall furnish from time to time such detailed drawings and other information as considered necessary, unless otherwise provided.

- (b) Wherever in the specifications or upon the drawings the words "directed", "required", "ordered", "designated", "prescribed", or words of like import are used, it shall be understood that the "direction", "requirement", "order", "designation", or "prescription", of the Contracting Officer is intended and similarly the words "approved", "acceptable", "satisfactory", or words of like import shall mean "approved by", or "acceptable to", or "satisfactory to" the Contracting Officer, unless otherwise expressly stated.
- (c) Where "shown" "indicated", "detailed", or words of similar import are used, it shall be understood that the reference is made to the drawings accompanying this contract unless stated otherwise. The word "provided" as used herein shall be understood to mean "provide complete in place" that is "furnished and installed".
- (d) "Shop drawings" means drawings, submitted to the PHA by the Contractor, subcontractor, or any lower tier subcontractor, showing in detail (1) the proposed fabrication and assembly of structural elements and (2) the installation (i.e., form, fit, and attachment details) of materials of equipment. It includes drawings, diagrams, layouts, schematics, descriptive literature, illustrations, schedules, performance and test data, and similar materials furnished by the Contractor to explain in detail specific portions of the work required by the contract. The PHA may duplicate, use, and disclose in any manner and for any purpose shop drawings delivered under this contract.
- (e) If this contract requires shop drawings, the Contractor shall coordinate all such drawings, and review them for accuracy, completeness, and compliance with other contract requirements and shall indicate its approval thereon as evidence of such coordination and review. Shop drawings submitted to the Contracting Officer without evidence of the Contractor's approval may be returned for resubmission. The Contracting Officer will indicate an approval or disapproval of the shop drawings and if not approved as submitted shall indicate the PHA's reasons therefore. Any work done before such approval shall be at the Contractor's risk. Approval by the Contracting Officer shall not relieve the Contractor from responsibility for any errors or omissions in such drawings, nor from responsibility for complying with the requirements of this contract, except with respect to variations described and approved in accordance with (f) below.
- (f) If shop drawings show variations from the contract requirements, the Contractor shall describe such variations in writing, separate from the drawings, at the time of submission. If the Architect approves any such variation and the Contracting Officer concurs, the Contracting Officer shall issue an appropriate modification to the contract, except that, if the variation is minor or does not involve a change in price or in time of performance, a modification need not be issued.
- (g) It shall be the responsibility of the Contractor to make timely requests of the PHA for such large scale and full size drawings, color schemes, and other additional information, not already in his possession, which shall be

required in the planning and production of the work. Such requests may be submitted as the need arises, but each such request shall be filed in ample time to permit appropriate action to be taken by all parties involved so as to avoid delay.

- (h) The Contractor shall submit to the Contracting Officer for approval four copies (unless otherwise indicated) of all shop drawings as called for under the various headings of these specifications. Three sets (unless otherwise indicated) of all shop drawings, will be retained by the PHA and one set will be returned to the Contractor. As required by the Contracting Officer, the Contractor, upon completing the work under this contract, shall furnish a complete set of all shop drawings as finally approved. These drawings shall show all changes and revisions made up to the time the work is completed and accepted.
- (i) This clause shall be included in all subcontracts at any tier. It shall be the responsibility of the Contractor to ensure that all shop drawings prepared by subcontractors are submitted to the Contracting Officer.

10. As-Built Drawings

- (a) "As-built drawings," as used in this clause, means drawings submitted by the Contractor or subcontractor at any tier to show the construction of a particular structure or work as actually completed under the contract. "As-built drawings" shall be synonymous with "Record drawings."
- (b) As required by the Contracting Officer, the Contractor shall provide the Contracting Officer accurate information to be used in the preparation of permanent as-built drawings. For this purpose, the Contractor shall record on one set of contract drawings all changes from the installations originally indicated, and record final locations of underground lines by depth from finish grade and by accurate horizontal offset distances to permanent surface improvements such as buildings, curbs, or edges of walks.
- (c) This clause shall be included in all subcontracts at any tier. It shall be the responsibility of the Contractor to ensure that all as-built drawings prepared by subcontractors are submitted to the Contracting Officer.

11. Material and Workmanship

- (a) All equipment, material, and articles furnished under this contract shall be new and of the most suitable grade for the purpose intended, unless otherwise specifically provided in this contract. References in the contract to equipment, material, articles, or patented processes by trade name, make, or catalog number, shall be regarded as establishing a standard of quality and shall not be construed as limiting competition. The Contractor may, at its option, use any equipment, material, article, or process that, in the judgment of, and as approved by the Contracting Officer, is equal to that named in the specifications, unless otherwise specifically provided in this contract.
- (b) Approval of equipment and materials.
 - (1) The Contractor shall obtain the Contracting Officer's approval of the machinery and mechanical and other equipment to be incorporated into the work. When requesting approval, the Contractor shall furnish to the Contracting Officer the name of the manufacturer, the model number, and other information concerning the performance, capacity, nature, and rating of the

machinery and mechanical and other equipment. When required by this contract or by the Contracting Officer, the Contractor shall also obtain the Contracting Officer's approval of the material or articles which the Contractor contemplates incorporating into the work. When requesting approval, the Contractor shall provide full information concerning the material or articles. Machinery, equipment, material, and articles that do not have the required approval shall be installed or used at the risk of subsequent rejection.

- (2) When required by the specifications or the Contracting Officer, the Contractor shall submit appropriately marked samples (and certificates related to them) for approval at the Contractor's expense, with all shipping charges prepaid. The Contractor shall label, or otherwise properly mark on the container, the material or product represented, its place of origin, the name of the producer, the Contractor's name, and the identification of the construction project for which the material or product is intended to be used.
- (3) Certificates shall be submitted in triplicate, describing each sample submitted for approval and certifying that the material, equipment or accessory complies with contract requirements. The certificates shall include the name and brand of the product, name of manufacturer, and the location where produced.
- (4) Approval of a sample shall not constitute a waiver of the PHA right to demand full compliance with contract requirements. Materials, equipment and accessories may be rejected for cause even though samples have been approved.
- (5) Wherever materials are required to comply with recognized standards or specifications, such specifications shall be accepted as establishing the technical qualities and testing methods, but shall not govern the number of tests required to be made nor modify other contract requirements. The Contracting Officer may require laboratory test reports on items submitted for approval or may approve materials on the basis of data submitted in certificates with samples. Check tests will be made on materials delivered for use only as frequently as the Contracting Officer determines necessary to insure compliance of materials with the specifications. The Contractor will assume all costs of retesting materials which fail to meet contract requirements and/or testing materials offered in substitution for those found deficient.
- (6) After approval, samples will be kept in the Project office until completion of work. They may be built into the work after a substantial quantity of the materials they represent has been built in and accepted.
- (c) Requirements concerning lead-based paint. The Contractor shall comply with the requirements concerning lead-based paint contained in the Lead-Based Paint Poisoning Prevention Act (42 U.S.C. 4821-4846) as implemented by 24 CFR Part 35.

12. Permits and Codes

- (a) The Contractor shall give all notices and comply with all applicable laws, ordinances, codes, rules and regulations. Notwithstanding the requirement of the Contractor to comply with the drawings and specifications in the contract, all work installed shall comply with all applicable codes and regulations as amended by any

waivers. Before installing the work, the Contractor shall examine the drawings and the specifications for compliance with applicable codes and regulations bearing on the work and shall immediately report any discrepancy it may discover to the Contracting Officer. Where the requirements of the drawings and specifications fail to comply with the applicable code or regulation, the Contracting Officer shall modify the contract by change order pursuant to the clause entitled Changes herein to conform to the code or regulation.

- (b) The Contractor shall secure and pay for all permits, fees, and licenses necessary for the proper execution and completion of the work. Where the PHA can arrange for the issuance of all or part of these permits, fees and licenses, without cost to the Contractor, the contract amount shall be reduced accordingly.

13. Health, Safety, and Accident Prevention

- (a) In performing this contract, the Contractor shall:
 - (1) Ensure that no laborer or mechanic shall be required to work in surroundings or under working conditions which are unsanitary, hazardous, or dangerous to his/her health and/or safety as determined under construction safety and health standards promulgated by the Secretary of Labor by regulation;
 - (2) Protect the lives, health, and safety of other persons;
 - (3) Prevent damage to property, materials, supplies, and equipment; and,
 - (4) Avoid work interruptions.
- (b) For these purposes, the Contractor shall:
 - (1) Comply with regulations and standards issued by the Secretary of Labor at 29 CFR Part 1926. Failure to comply may result in imposition of sanctions pursuant to the Contract Work Hours and Safety Standards Act (Public Law 91-54, 83 Stat. 96), 40 U.S.C. 3701 et seq.; and
 - (2) Include the terms of this clause in every subcontract so that such terms will be binding on each subcontractor.
- (c) The Contractor shall maintain an accurate record of exposure data on all accidents incident to work performed under this contract resulting in death, traumatic injury, occupational disease, or damage to property, materials, supplies, or equipment, and shall report this data in the manner prescribed by 29 CFR Part 1904.
- (d) The Contracting Officer shall notify the Contractor of any noncompliance with these requirements and of the corrective action required. This notice, when delivered to the Contractor or the Contractor's representative at the site of the work, shall be deemed sufficient notice of the noncompliance and corrective action required. After receiving the notice, the Contractor shall immediately take corrective action. If the Contractor fails or refuses to take corrective action promptly, the Contracting Officer may issue an order stopping all or part of the work until satisfactory corrective action has been taken. The Contractor shall not base any claim or request for equitable adjustment for additional time or money on any stop order issued under these circumstances.
- (e) The Contractor shall be responsible for its subcontractors' compliance with the provisions of this clause. The Contractor shall take such action with respect to any subcontract as the PHA, the Secretary of Housing and Urban Development, or the Secretary of Labor shall direct as a means of enforcing such provisions.

14. Temporary Heating

The Contractor shall provide and pay for temporary heating, covering, and enclosures necessary to properly protect all work and materials against damage by dampness and cold, to dry out the work, and to facilitate the completion of the work. Any permanent heating equipment used shall be turned over to the PHA in the condition and at the time required by the specifications.

15. Availability and Use of Utility Services

- (a) The PHA shall make all reasonably required amounts of utilities available to the Contractor from existing outlets and supplies, as specified in the contract. Unless otherwise provided in the contract, the amount of each utility service consumed shall be charged to or paid for by the Contractor at prevailing rates charged to the PHA or, where the utility is produced by the PHA, at reasonable rates determined by the Contracting Officer. The Contractor shall carefully conserve any utilities furnished without charge.
- (b) The Contractor, at its expense and in a manner satisfactory to the Contracting Officer, shall install and maintain all necessary temporary connections and distribution lines, and all meters required to measure the amount of each utility used for the purpose of determining charges. Before final acceptance of the work by the PHA, the Contractor shall remove all the temporary connections, distribution lines, meters, and associated paraphernalia.

16. Protection of Existing Vegetation, Structures, Equipment, Utilities, and Improvements

- (a) The Contractor shall preserve and protect all structures, equipment, and vegetation (such as trees, shrubs, and grass) on or adjacent to the work site, which are not to be removed under this contract, and which do not unreasonably interfere with the work required under this contract.
- (b) The Contractor shall only remove trees when specifically authorized to do so, and shall avoid damaging vegetation that will remain in place. If any limbs or branches of trees are broken during performance of this contract, or by the careless operation of equipment, or by workmen, the Contractor shall trim those limbs or branches with a clean cut and paint the cut with a tree-pruning compound as directed by the Contracting Officer.
- (c) The Contractor shall protect from damage all existing improvements and utilities (1) at or near the work site and (2) on adjacent property of a third party, the locations of which are made known to or should be known by the Contractor. Prior to disturbing the ground at the construction site, the Contractor shall ensure that all underground utility lines are clearly marked.
- (d) The Contractor shall shore up, brace, underpin, secure, and protect as necessary all foundations and other parts of existing structures adjacent to, adjoining, and in the vicinity of the site, which may be affected by the excavations or other operations connected with the construction of the project.
- (e) Any equipment temporarily removed as a result of work under this contract shall be protected, cleaned, and replaced in the same condition as at the time of award of this contract.

- (f) New work which connects to existing work shall correspond in all respects with that to which it connects and/or be similar to existing work unless otherwise required by the specifications.
- (g) No structural members shall be altered or in any way weakened without the written authorization of the Contracting Officer, unless such work is clearly specified in the plans or specifications.
- (h) If the removal of the existing work exposes discolored or unfinished surfaces, or work out of alignment, such surfaces shall be refinished, or the material replaced as necessary to make the continuous work uniform and harmonious. This, however, shall not be construed to require the refinishing or reconstruction of dissimilar finishes previously exposed, or finished surfaces in good condition, but in different planes or on different levels when brought together by the removal of intervening work, unless such refinishing or reconstruction is specified in the plans or specifications.
- (i) The Contractor shall give all required notices to any adjoining or adjacent property owner or other party before the commencement of any work.
- (j) The Contractor shall indemnify and save harmless the PHA from any damages on account of settlement or the loss of lateral support of adjoining property, any damages from changes in topography affecting drainage, and from all loss or expense and all damages for which the PHA may become liable in consequence of such injury or damage to adjoining and adjacent structures and their premises.
- (k) The Contractor shall repair any damage to vegetation, structures, equipment, utilities, or improvements, including those that are the property of a third party, resulting from failure to comply with the requirements of this contract or failure to exercise reasonable care in performing the work. If the Contractor fails or refuses to repair the damage promptly, the Contracting Officer may have the necessary work performed and charge the cost to the Contractor.

17. Temporary Buildings and Transportation of Materials

- (a) Temporary buildings (e.g., storage sheds, shops, offices, sanitary facilities) and utilities may be erected by the Contractor only with the approval of the Contracting Officer and shall be built with labor and materials furnished by the Contractor without expense to the PHA. The temporary buildings and utilities shall remain the property of the Contractor and shall be removed by the Contractor at its expense upon completion of the work. With the written consent of the Contracting Officer, the buildings and utilities may be abandoned and need not be removed.
- (b) The Contractor shall, as directed by the Contracting Officer, use only established roadways, or use temporary roadways constructed by the Contractor when and as authorized by the Contracting Officer. When materials are transported in prosecuting the work, vehicles shall not be loaded beyond the loading capacity recommended by the manufacturer of the vehicle or prescribed by any federal, state, or local law or regulation. When it is necessary to cross curbs or sidewalks, the Contractor shall protect them from damage. The Contractor shall repair or pay for the repair of any damaged curbs, sidewalks, or roads.

18. Clean Air and Water

The contractor shall comply with the Clean Air Act, as amended, 42 USC 7401 et seq., the Federal Water Pollution Control Water Act, as amended, 33 U.S.C. 1251 et seq., and standards issued pursuant thereto in the facilities in which this contract is to be performed.

19. Energy Efficiency

The Contractor shall comply with mandatory standards and policies relating to energy efficiency which are contained in the energy conservation plan issued in compliance with the Energy Policy and Conservation Act (Pub.L. 94-163) for the State in which the work under the contract is performed.

20. Inspection and Acceptance of Construction

- (a) Definitions. As used in this clause -
 - (1) "Acceptance" means the act of an authorized representative of the PHA by which the PHA approves and assumes ownership of the work performed under this contract. Acceptance may be partial or complete.
 - (2) "Inspection" means examining and testing the work performed under the contract (including, when appropriate, raw materials, equipment, components, and intermediate assemblies) to determine whether it conforms to contract requirements.
 - (3) "Testing" means that element of inspection that determines the properties or elements, including functional operation of materials, equipment, or their components, by the application of established scientific principles and procedures.
- (b) The Contractor shall maintain an adequate inspection system and perform such inspections as will ensure that the work performed under the contract conforms to contract requirements. All work is subject to PHA inspection and test at all places and at all reasonable times before acceptance to ensure strict compliance with the terms of the contract.
- (c) PHA inspections and tests are for the sole benefit of the PHA and do not: (1) relieve the Contractor of responsibility for providing adequate quality control measures; (2) relieve the Contractor of responsibility for loss or damage of the material before acceptance; (3) constitute or imply acceptance; or, (4) affect the continuing rights of the PHA after acceptance of the completed work under paragraph (j) below.
- (d) The presence or absence of the PHA inspector does not relieve the Contractor from any contract requirement, nor is the inspector authorized to change any term or condition of the specifications without the Contracting Officer's written authorization. All instructions and approvals with respect to the work shall be given to the Contractor by the Contracting Officer.
- (e) The Contractor shall promptly furnish, without additional charge, all facilities, labor, and material reasonably needed for performing such safe and convenient inspections and tests as may be required by the Contracting Officer. The PHA may charge to the Contractor any additional cost of inspection or test when work is not ready at the time specified by the Contractor for inspection or test, or when prior rejection makes reinspection or retest necessary. The PHA shall perform all inspections and tests in a manner that will not unnecessarily delay the work. Special, full size, and performance tests shall be performed as described in the contract.

- (f) The PHA may conduct routine inspections of the construction site on a daily basis.
- (g) The Contractor shall, without charge, replace or correct work found by the PHA not to conform to contract requirements, unless the PHA decides that it is in its interest to accept the work with an appropriate adjustment in contract price. The Contractor shall promptly segregate and remove rejected material from the premises.
- (h) If the Contractor does not promptly replace or correct rejected work, the PHA may (1) by contract or otherwise, replace or correct the work and charge the cost to the Contractor, or (2) terminate for default the Contractor's right to proceed.
- (i) If any work requiring inspection is covered up without approval of the PHA, it must, if requested by the Contracting Officer, be uncovered at the expense of the Contractor. If at any time before final acceptance of the entire work, the PHA considers it necessary or advisable, to examine work already completed by removing or tearing it out, the Contractor, shall on request, promptly furnish all necessary facilities, labor, and material. If such work is found to be defective or nonconforming in any material respect due to the fault of the Contractor or its subcontractors, the Contractor shall defray all the expenses of the examination and of satisfactory reconstruction. If, however, such work is found to meet the requirements of the contract, the Contracting Officer shall make an equitable adjustment to cover the cost of the examination and reconstruction, including, if completion of the work was thereby delayed, an extension of time.
- (j) The Contractor shall notify the Contracting Officer, in writing, as to the date when in its opinion all or a designated portion of the work will be substantially completed and ready for inspection. If the Architect determines that the state of preparedness is as represented, the PHA will promptly arrange for the inspection. Unless otherwise specified in the contract, the PHA shall accept, as soon as practicable after completion and inspection, all work required by the contract or that portion of the work the Contracting Officer determines and designates can be accepted separately. Acceptance shall be final and conclusive except for latent defects, fraud, gross mistakes amounting to fraud, or the PHA's right under any warranty or guarantee.

21. Use and Possession Prior to Completion

- (a) The PHA shall have the right to take possession of or use any completed or partially completed part of the work. Before taking possession of or using any work, the Contracting Officer shall furnish the Contractor a list of items of work remaining to be performed or corrected on those portions of the work that the PHA intends to take possession of or use. However, failure of the Contracting Officer to list any item of work shall not relieve the Contractor of responsibility for complying with the terms of the contract. The PHA's possession or use shall not be deemed an acceptance of any work under the contract.
- (b) While the PHA has such possession or use, the Contractor shall be relieved of the responsibility for (1) the loss of or damage to the work resulting from the PHA's possession or use, notwithstanding the terms of the clause entitled Permits and Codes herein; (2) all maintenance costs on the areas occupied; and, (3) furnishing heat, light, power, and water used in the areas

occupied without proper remuneration therefore. If prior possession or use by the PHA delays the progress of the work or causes additional expense to the Contractor, an equitable adjustment shall be made in the contract price or the time of completion, and the contract shall be modified in writing accordingly.

22. Warranty of Title

The Contractor warrants good title to all materials, supplies, and equipment incorporated in the work and agrees to deliver the premises together with all improvements thereon free from any claims, liens or charges, and agrees further that neither it nor any other person, firm or corporation shall have any right to a lien upon the premises or anything appurtenant thereto.

23. Warranty of Construction

- (a) In addition to any other warranties in this contract, the Contractor warrants, except as provided in paragraph (j) of this clause, that work performed under this contract conforms to the contract requirements and is free of any defect in equipment, material, or workmanship performed by the Contractor or any subcontractor or supplier at any tier. This warranty shall continue for a period of _____ (**one year**) from the date of final acceptance of the work. If the PHA takes possession of any part of the work before final acceptance, this warranty shall continue for a period of (one year unless otherwise indicated) from the date that the PHA takes possession.
- (b) The Contractor shall remedy, at the Contractor's expense, any failure to conform, or any defect. In addition, the Contractor shall remedy, at the Contractor's expense, any damage to PHA-owned or controlled real or personal property when the damage is the result of—
 - (1) The Contractor's failure to conform to contract requirements; or
 - (2) Any defects of equipment, material, workmanship or design furnished by the Contractor.
- (c) The Contractor shall restore any work damaged in fulfilling the terms and conditions of this clause. The Contractor's warranty with respect to work repaired or replaced will run for (one year unless otherwise indicated) from the date of repair or replacement.
- (d) The Contracting Officer shall notify the Contractor, in writing, within a reasonable time after the discovery of any failure, defect or damage.
- (e) If the Contractor fails to remedy any failure, defect, or damage within a reasonable time after receipt of notice, the PHA shall have the right to replace, repair or otherwise remedy the failure, defect, or damage at the Contractor's expense.
- (f) With respect to all warranties, express or implied, from subcontractors, manufacturers, or suppliers for work performed and materials furnished under this contract, the Contractor shall:
 - (1) Obtain all warranties that would be given in normal commercial practice;
 - (2) Require all warranties to be executed in writing, for the benefit of the PHA; and,
 - (3) Enforce all warranties for the benefit of the PHA.
- (g) In the event the Contractor's warranty under paragraph (a) of this clause has expired, the PHA may bring suit at its own expense to enforce a subcontractor's, manufacturer's or supplier's warranty.

- (h) Unless a defect is caused by the negligence of the Contractor or subcontractor or supplier at any tier, the Contractor shall not be liable for the repair of any defect of material or design furnished by the PHA nor for the repair of any damage that results from any defect in PHA furnished material or design.
- (i) Notwithstanding any provisions herein to the contrary, the establishment of the time periods in paragraphs (a) and (c) above relate only to the specific obligation of the Contractor to correct the work, and have no relationship to the time within which its obligation to comply with the contract may be sought to be enforced, nor to the time within which proceedings may be commenced to establish the Contractor's liability with respect to its obligation other than specifically to correct the work.
- (j) This warranty shall not limit the PHA's rights under the Inspection and Acceptance of Construction clause of this contract with respect to latent defects, gross mistakes or fraud.

24. Prohibition Against Liens

The Contractor is prohibited from placing a lien on the PHA's property. This prohibition shall apply to all subcontractors at any tier and all materials suppliers.

Administrative Requirements

25. Contract Period

The Contractor shall complete all work required on this contract within _____ calendar days of the effective date of the contract, or within the time schedule established in the notice to proceed issued by the Contracting Officer.

26. Order of Provisions

In the event of a conflict between these General Conditions and the Specifications, the General Conditions shall prevail. In the event of a conflict between the contract and any applicable state or local law or regulation, the state or local law or regulation shall prevail; provided that such state or local law or regulation does not conflict with, or is less restrictive than applicable federal law, regulation, or Executive Order. In the event of such a conflict, applicable federal law, regulation, and Executive Order shall prevail.

27. Payments

- (a) The PHA shall pay the Contractor the price as provided in this contract.
- (b) The PHA shall make progress payments approximately every 30 days as the work proceeds, on estimates of work accomplished which meets the standards of quality established under the contract, as approved by the Contracting Officer. The PHA may, subject to written determination and approval of the Contracting Officer, make more frequent payments to contractors which are qualified small businesses.
- (c) Before the first progress payment under this contract, the Contractor shall furnish, in such detail as requested by the Contracting Officer, a breakdown of the total contract price showing the amount included therein for each principal category of the work, which shall substantiate the payment amount requested in order to provide a

basis for determining progress payments. The breakdown shall be approved by the Contracting Officer and must be acceptable to HUD. If the contract covers more than one project, the Contractor shall furnish a separate breakdown for each. The values and quantities employed in making up this breakdown are for determining the amount of progress payments and shall not be construed as a basis for additions to or deductions from the contract price. The Contractor shall prorate its overhead and profit over the construction period of the contract.

- (d) The Contractor shall submit, on forms provided by the PHA, periodic estimates showing the value of the work performed during each period based upon the approved breakdown of the contract price. Such estimates shall be submitted not later than _____ 20 days in advance the date set for payment and are subject to correction and revision as required. The estimates must be approved by the Contracting Officer with the concurrence of the Architect prior to payment. If the contract covers more than one project, the Contractor shall furnish a separate progress payment estimate for each.
- (e) Along with each request for progress payments and the required estimates, the Contractor shall furnish the following certification, or payment shall not be made: I hereby certify, to the best of my knowledge and belief, that:
 - (1) The amounts requested are only for performance in accordance with the specifications, terms, and conditions of the contract;
 - (2) Payments to subcontractors and suppliers have been made from previous payments received under the contract, and timely payments will be made from the proceeds of the payment covered by this certification, in accordance with subcontract agreements; and,
 - (3) This request for progress payments does not include any amounts which the prime contractor intends to withhold or retain from a subcontractor or supplier in accordance with the terms and conditions of the subcontract.

Name:

Title:

Date:

- (f) Except as otherwise provided in State law, the PHA shall retain ten (10) percent of the amount of progress payments until completion and acceptance of all work under the contract; except, that if upon completion of 50 percent of the work, the Contracting Officer, after consulting with the Architect, determines that the Contractor's performance and progress are satisfactory, the PHA may make the remaining payments in full for the work subsequently completed. If the Contracting Officer subsequently determines that the Contractor's performance and progress are unsatisfactory, the PHA shall reinstate the ten (10) percent (or other percentage as provided in State law) retainage until such time as the Contracting Officer determines that performance and progress are satisfactory.
- (g) The Contracting Officer may authorize material delivered on the site and preparatory work done to be taken into consideration when computing progress payments.

Material delivered to the Contractor at locations other than the site may also be taken into consideration if the Contractor furnishes satisfactory evidence that (1) it has acquired title to such material; (2) the material is properly stored in a bonded warehouse, storage yard, or similar suitable place as may be approved by the Contracting Officer; (3) the material is insured to cover its full value; and (4) the material will be used to perform this contract. Before any progress payment which includes delivered material is made, the Contractor shall furnish such documentation as the Contracting Officer may require to assure the protection of the PHA's interest in such materials. The Contractor shall remain responsible for such stored material notwithstanding the transfer of title to the PHA.

- (h) All material and work covered by progress payments made shall, at the time of payment become the sole property of the PHA, but this shall not be construed as (1) relieving the Contractor from the sole responsibility for all material and work upon which payments have been made or the restoration of any damaged work; or, (2) waiving the right of the PHA to require the fulfillment of all of the terms of the contract. In the event the work of the Contractor has been damaged by other contractors or persons other than employees of the PHA in the course of their employment, the Contractor shall restore such damaged work without cost to the PHA and to seek redress for its damage only from those who directly caused it.
- (i) The PHA shall make the final payment due the Contractor under this contract after (1) completion and final acceptance of all work; and (2) presentation of release of all claims against the PHA arising by virtue of this contract, other than claims, in stated amounts, that the Contractor has specifically excepted from the operation of the release. Each such exception shall embrace no more than one claim, the basis and scope of which shall be clearly defined. The amounts for such excepted claims shall not be included in the request for final payment. A release may also be required of the assignee if the Contractor's claim to amounts payable under this contract has been assigned.
- (j) Prior to making any payment, the Contracting Officer may require the Contractor to furnish receipts or other evidence of payment from all persons performing work and supplying material to the Contractor, if the Contracting Officer determines such evidence is necessary to substantiate claimed costs.
- (k) The PHA shall not; (1) determine or adjust any claims for payment or disputes arising there under between the Contractor and its subcontractors or material suppliers; or, (2) withhold any moneys for the protection of the subcontractors or material suppliers. The failure or refusal of the PHA to withhold moneys from the Contractor shall in nowise impair the obligations of any surety or sureties under any bonds furnished under this contract.

28. Contract Modifications

- (a) Only the Contracting Officer has authority to modify any term or condition of this contract. Any contract modification shall be authorized in writing.
- (b) The Contracting Officer may modify the contract unilaterally (1) pursuant to a specific authorization stated in a contract clause (e.g., Changes); or (2) for administrative matters which do not change the rights or

responsibilities of the parties (e.g., change in the PHA address). All other contract modifications shall be in the form of supplemental agreements signed by the Contractor and the Contracting Officer.

- (c) When a proposed modification requires the approval of HUD prior to its issuance (e.g., a change order that exceeds the PHA's approved threshold), such modification shall not be effective until the required approval is received by the PHA.

29. Changes

- (a) The Contracting Officer may, at any time, without notice to the sureties, by written order designated or indicated to be a change order, make changes in the work within the general scope of the contract including changes:
 - (1) In the specifications (including drawings and designs);
 - (2) In the method or manner of performance of the work;
 - (3) PHA-furnished facilities, equipment, materials, services, or site; or,
 - (4) Directing the acceleration in the performance of the work.
- (b) Any other written order or oral order (which, as used in this paragraph (b), includes direction, instruction, interpretation, or determination) from the Contracting Officer that causes a change shall be treated as a change order under this clause; provided, that the Contractor gives the Contracting Officer written notice stating (1) the date, circumstances and source of the order and (2) that the Contractor regards the order as a change order.
- (c) Except as provided in this clause, no order, statement or conduct of the Contracting Officer shall be treated as a change under this clause or entitle the Contractor to an equitable adjustment.
- (d) If any change under this clause causes an increase or decrease in the Contractor's cost of, or the time required for the performance of any part of the work under this contract, whether or not changed by any such order, the Contracting Officer shall make an equitable adjustment and modify the contract in writing. However, except for an adjustment based on defective specifications, no proposal for any change under paragraph (b) above shall be allowed for any costs incurred more than 20 days (5 days for oral orders) before the Contractor gives written notice as required. In the case of defective specifications for which the PHA is responsible, the equitable adjustment shall include any increased cost reasonably incurred by the Contractor in attempting to comply with the defective specifications.
- (e) The Contractor must assert its right to an adjustment under this clause within 30 days after (1) receipt of a written change order under paragraph (a) of this clause, or (2) the furnishing of a written notice under paragraph (b) of this clause, by submitting a written statement describing the general nature and the amount of the proposal. If the facts justify it, the Contracting Officer may extend the period for submission. The proposal may be included in the notice required under paragraph (b) above. No proposal by the Contractor for an equitable adjustment shall be allowed if asserted after final payment under this contract.
- (f) The Contractor's written proposal for equitable adjustment shall be submitted in the form of a lump sum proposal supported with an itemized breakdown of all increases and decreases in the contract in at least the following details:

- (1) Direct Costs. Materials (list individual items, the quantity and unit cost of each, and the aggregate cost); Transportation and delivery costs associated with materials; Labor breakdowns by hours or unit costs (identified with specific work to be performed); Construction equipment exclusively necessary for the change; Costs of preparation and/ or revision to shop drawings resulting from the change; Worker's Compensation and Public Liability Insurance; Employment taxes under FICA and FUTA; and, Bond Costs when size of change warrants revision.
- (2) Indirect Costs. Indirect costs may include overhead, general and administrative expenses, and fringe benefits not normally treated as direct costs.
- (3) Profit. The amount of profit shall be negotiated and may vary according to the nature, extent, and complexity of the work required by the change. The allowability of the direct and indirect costs shall be determined in accordance with the Contract Cost Principles and Procedures for Commercial Firms in Part 31 of the Federal Acquisition Regulation (48 CFR 1-31), as implemented by HUD Handbook 2210.18, in effect on the date of this contract. The Contractor shall not be allowed a profit on the profit received by any subcontractor. Equitable adjustments for deleted work shall include a credit for profit and may include a credit for indirect costs. On proposals covering both increases and decreases in the amount of the contract, the application of indirect costs and profit shall be on the net-change in direct costs for the Contractor or subcontractor performing the work.
- (g) The Contractor shall include in the proposal its request for time extension (if any), and shall include sufficient information and dates to demonstrate whether and to what extent the change will delay the completion of the contract in its entirety.
- (h) The Contracting Officer shall act on proposals within 30 days after their receipt, or notify the Contractor of the date when such action will be taken.
- (i) Failure to reach an agreement on any proposal shall be a dispute under the clause entitled Disputes herein. Nothing in this clause, however, shall excuse the Contractor from proceeding with the contract as changed.
- (j) Except in an emergency endangering life or property, no change shall be made by the Contractor without a prior order from the Contracting Officer.

30. Suspension of Work

- (a) The Contracting Officer may order the Contractor in writing to suspend, delay, or interrupt all or any part of the work of this contract for the period of time that the Contracting Officer determines appropriate for the convenience of the PHA.
- (b) If the performance of all or any part of the work is, for an unreasonable period of time, suspended, delayed, or interrupted (1) by an act of the Contracting Officer in the administration of this contract, or (2) by the Contracting Officer's failure to act within the time specified (or within a reasonable time if not specified) in this contract an adjustment shall be made for any increase in the cost of performance of the contract (excluding profit) necessarily caused by such unreasonable suspension, delay, or interruption and the contract modified in writing accordingly. However, no adjustment shall be made under this clause for any suspension, delay, or interruption to the extent that performance would have

been so suspended, delayed, or interrupted by any other cause, including the fault or negligence of the Contractor or for which any equitable adjustment is provided for or excluded under any other provision of this contract.

- (c) A claim under this clause shall not be allowed (1) for any costs incurred more than 20 days before the Contractor shall have notified the Contracting Officer in writing of the act or failure to act involved (but this requirement shall not apply as to a claim resulting from a suspension order); and, (2) unless the claim, in an amount stated, is asserted in writing as soon as practicable after the termination of the suspension, delay, or interruption, but not later than the date of final payment under the contract.

31. Disputes

- (a) "Claim," as used in this clause, means a written demand or written assertion by one of the contracting parties seeking, as a matter of right, the payment of money in a sum certain, the adjustment or interpretation of contract terms, or other relief arising under or relating to the contract. A claim arising under the contract, unlike a claim relating to the contract, is a claim that can be resolved under a contract clause that provides for the relief sought by the claimant. A voucher, invoice, or other routine request for payment that is not in dispute when submitted is not a claim. The submission may be converted to a claim by complying with the requirements of this clause, if it is disputed either as to liability or amount or is not acted upon in a reasonable time.
- (b) Except for disputes arising under the clauses entitled Labor Standards - Davis Bacon and Related Acts, herein, all disputes arising under or relating to this contract, including any claims for damages for the alleged breach thereof which are not disposed of by agreement, shall be resolved under this clause.
- (c) All claims by the Contractor shall be made in writing and submitted to the Contracting Officer for a written decision. A claim by the PHA against the Contractor shall be subject to a written decision by the Contracting Officer.
- (d) The Contracting Officer shall, within 60 (unless otherwise indicated) days after receipt of the request, decide the claim or notify the Contractor of the date by which the decision will be made.
- (e) The Contracting Officer's decision shall be final unless the Contractor (1) appeals in writing to a higher level in the PHA in accordance with the PHA's policy and procedures, (2) refers the appeal to an independent mediator or arbitrator, or (3) files suit in a court of competent jurisdiction. Such appeal must be made within (30 unless otherwise indicated) days after receipt of the Contracting Officer's decision.
- (f) The Contractor shall proceed diligently with performance of this contract, pending final resolution of any request for relief, claim, appeal, or action arising under or relating to the contract, and comply with any decision of the Contracting Officer.

32. Default

- (a) If the Contractor refuses or fails to prosecute the work, or any separable part thereof, with the diligence that will insure its completion within the time specified in this contract, or any extension thereof, or fails to complete said work within this time, the Contracting Officer may, by written notice to the Contractor, terminate the right to

proceed with the work (or separable part of the work) that has been delayed. In this event, the PHA may take over the work and complete it, by contract or otherwise, and may take possession of and use any materials, equipment, and plant on the work site necessary for completing the work. The Contractor and its sureties shall be liable for any damage to the PHA resulting from the Contractor's refusal or failure to complete the work within the specified time, whether or not the Contractor's right to proceed with the work is terminated. This liability includes any increased costs incurred by the PHA in completing the work.

- (b) The Contractor's right to proceed shall not be terminated or the Contractor charged with damages under this clause if—
- (1) The delay in completing the work arises from unforeseeable causes beyond the control and without the fault or negligence of the Contractor. Examples of such causes include (i) acts of God, or of the public enemy, (ii) acts of the PHA or other governmental entity in either its sovereign or contractual capacity, (iii) acts of another contractor in the performance of a contract with the PHA, (iv) fires, (v) floods, (vi) epidemics, (vii) quarantine restrictions, (viii) strikes, (ix) freight embargoes, (x) unusually severe weather, or (xi) delays of subcontractors or suppliers at any tier arising from unforeseeable causes beyond the control and without the fault or negligence of both the Contractor and the subcontractors or suppliers; and
 - (2) The Contractor, within days (10 days unless otherwise indicated) from the beginning of such delay (unless extended by the Contracting Officer) notifies the Contracting Officer in writing of the causes of delay. The Contracting Officer shall ascertain the facts and the extent of the delay. If, in the judgment of the Contracting Officer, the findings of fact warrant such action, time for completing the work shall be extended by written modification to the contract. The findings of the Contracting Officer shall be reduced to a written decision which shall be subject to the provisions of the Disputes clause of this contract.
- (c) If, after termination of the Contractor's right to proceed, it is determined that the Contractor was not in default, or that the delay was excusable, the rights and obligations of the parties will be the same as if the termination had been for convenience of the PHA.

33. Liquidated Damages

- (a) If the Contractor fails to complete the work within the time specified in the contract, or any extension, as specified in the clause entitled Default of this contract, the Contractor shall pay to the PHA as liquidated damages, the sum of \$ _____ for each day of delay. If different completion dates are specified in the contract for separate parts or stages of the work, the amount of liquidated damages shall be assessed on those parts or stages which are delayed. To the extent that the Contractor's delay or nonperformance is excused under another clause in this contract, liquidated damages shall not be due the PHA. The Contractor remains liable for damages caused other than by delay.
- (b) If the PHA terminates the Contractor's right to proceed, the resulting damage will consist of liquidated damages until such reasonable time as may be required for final

completion of the work together with any increased costs occasioned the PHA in completing the work.

- (c) If the PHA does not terminate the Contractor's right to proceed, the resulting damage will consist of liquidated damages until the work is completed or accepted.

34. Termination for Convenience

- (a) The Contracting Officer may terminate this contract in whole, or in part, whenever the Contracting Officer determines that such termination is in the best interest of the PHA. Any such termination shall be effected by delivery to the Contractor of a Notice of Termination specifying the extent to which the performance of the work under the contract is terminated, and the date upon which such termination becomes effective.
- (b) If the performance of the work is terminated, either in whole or in part, the PHA shall be liable to the Contractor for reasonable and proper costs resulting from such termination upon the receipt by the PHA of a properly presented claim setting out in detail: (1) the total cost of the work performed to date of termination less the total amount of contract payments made to the Contractor; (2) the cost (including reasonable profit) of settling and paying claims under subcontracts and material orders for work performed and materials and supplies delivered to the site, payment for which has not been made by the PHA to the Contractor or by the Contractor to the subcontractor or supplier; (3) the cost of preserving and protecting the work already performed until the PHA or assignee takes possession thereof or assumes responsibility therefore; (4) the actual or estimated cost of legal and accounting services reasonably necessary to prepare and present the termination claim to the PHA; and (5) an amount constituting a reasonable profit on the value of the work performed by the Contractor.
- (c) The Contracting Officer will act on the Contractor's claim within days (60 days unless otherwise indicated) of receipt of the Contractor's claim.
- (d) Any disputes with regard to this clause are expressly made subject to the provisions of the Disputes clause of this contract.

35. Assignment of Contract

The Contractor shall not assign or transfer any interest in this contract; except that claims for monies due or to become due from the PHA under the contract may be assigned to a bank, trust company, or other financial institution. Such assignments of claims shall only be made with the written concurrence of the Contracting Officer. If the Contractor is a partnership, this contract shall inure to the benefit of the surviving or remaining member(s) of such partnership as approved by the Contracting Officer.

36. Insurance

- (a) Before commencing work, the Contractor and each subcontractor shall furnish the PHA with certificates of insurance showing the following insurance is in force and will insure all operations under the Contract:
- (1) Workers' Compensation, in accordance with state or Territorial Workers' Compensation laws.
 - (2) Commercial General Liability with a combined single limit for bodily injury and property damage of not less than \$ _____ **\$1,000,000.00**

per occurrence to protect the Contractor and each subcontractor against claims for bodily injury or death and damage to the property of others. This shall cover the use of all equipment, hoists, and vehicles on the site(s) not covered by Automobile Liability under (3) below. If the Contractor has a "made" policy, then the following additional requirements apply: the policy must provide a "retroactive date" which must be on or before the execution date of the Contract; and the extended reporting period may not be less than five years following the completion date of the Contract.

- (3) Automobile Liability on owned and non-owned motor vehicles used on the site(s) or in connection therewith for a combined single limit for bodily injury and property damage of not less than \$ _____ **\$1,000,000.00** per occurrence.
- (b) Before commencing work, the Contractor shall furnish the PHA with a certificate of insurance evidencing that Builder's Risk (fire and extended coverage) Insurance on all work in place and/or materials stored at the building site(s), including foundations and building equipment, is in force. The Builder's Risk Insurance shall be for the benefit of the Contractor and the PHA as their interests may appear and each shall be named in the policy or policies as an insured. The Contractor in installing equipment supplied by the PHA shall carry insurance on such equipment from the time the Contractor takes possession thereof until the Contract work is accepted by the PHA. The Builder's Risk Insurance need not be carried on excavations, piers, footings, or foundations until such time as work on the superstructure is started. It need not be carried on landscape work. Policies shall furnish coverage at all times for the full cash value of all completed construction, as well as materials in place and/or stored at the site(s), whether or not partial payment has been made by the PHA. The Contractor may terminate this insurance on buildings as of the date taken over for occupancy by the PHA. The Contractor is not required to carry Builder's Risk Insurance for modernization work which does not involve structural alterations or additions and where the PHA's existing fire and extended coverage policy can be endorsed to include such work.
- (c) All insurance shall be carried with companies which are financially responsible and admitted to do business in the State in which the project is located. If any such insurance is due to expire during the construction period, the Contractor (including subcontractors, as applicable) shall not permit the coverage to lapse and shall furnish evidence of coverage to the Contracting Officer. All certificates of insurance, as evidence of coverage, shall provide that no coverage may be canceled or non-renewed by the insurance company until at least 30 days prior written notice has been given to the Contracting Officer.

37. Subcontracts

- (a) Definitions. As used in this contract -
- (1) "Subcontract" means any contract, purchase order, or other purchase agreement, including modifications and change orders to the foregoing, entered into by a subcontractor to furnish supplies, materials, equipment, and services for the performance of the prime contract or a subcontract.

(2) "Subcontractor" means any supplier, vendor, or firm that furnishes supplies, materials, equipment, or services to or for the Contractor or another subcontractor.

- (b) The Contractor shall not enter into any subcontract with any subcontractor who has been temporarily denied participation in a HUD program or who has been suspended or debarred from participating in contracting programs by any agency of the United States Government or of the state in which the work under this contract is to be performed.
- (c) The Contractor shall be as fully responsible for the acts or omissions of its subcontractors, and of persons either directly or indirectly employed by them as for the acts or omissions of persons directly employed by the Contractor.
- (d) The Contractor shall insert appropriate clauses in all subcontracts to bind subcontractors to the terms and conditions of this contract insofar as they are applicable to the work of subcontractors.
- (e) Nothing contained in this contract shall create any contractual relationship between any subcontractor and the PHA or between the subcontractor and HUD.

38. Subcontracting with Small and Minority Firms, Women's Business Enterprise, and Labor Surplus Area Firms

The Contractor shall take the following steps to ensure that, whenever possible, subcontracts are awarded to small business firms, minority firms, women's business enterprises, and labor surplus area firms:

- (a) Placing qualified small and minority businesses and women's business enterprises on solicitation lists;
- (b) Ensuring that small and minority businesses and women's business enterprises are solicited whenever they are potential sources;
- (c) Dividing total requirements, when economically feasible, into smaller tasks or quantities to permit maximum participation by small and minority businesses and women's business enterprises;
- (d) Establishing delivery schedules, where the requirements of the contract permit, which encourage participation by small and minority businesses and women's business enterprises; and
- (e) Using the services and assistance of the U.S. Small Business Administration, the Minority Business Development Agency of the U.S. Department of Commerce, and State and local governmental small business agencies.

39. Equal Employment Opportunity

During the performance of this contract, the Contractor agrees as follows:

- (a) The Contractor shall not discriminate against any employee or applicant for employment because of race, color, religion, sex, national origin, or handicap.
- (b) The Contractor shall take affirmative action to ensure that applicants are employed, and that employees are treated during employment without regard to their race, color, religion, sex, national origin, or handicap. Such action shall include, but not be limited to, (1) employment, (2) upgrading, (3) demotion, (4) transfer, (5) recruitment or recruitment advertising, (6) layoff or termination, (7) rates of pay or other forms of compensation, and (8) selection for training, including apprenticeship.

- (c) The Contractor shall post in conspicuous places available to employees and applicants for employment the notices to be provided by the Contracting Officer that explain this clause.
- (d) The Contractor shall, in all solicitations or advertisements for employees placed by or on behalf of the Contractor, state that all qualified applicants will receive consideration for employment without regard to race, color, religion, sex, national origin, or handicap.
- (e) The Contractor shall send, to each labor union or representative of workers with which it has a collective bargaining agreement or other contract or understanding, the notice to be provided by the Contracting Officer advising the labor union or workers' representative of the Contractor's commitments under this clause, and post copies of the notice in conspicuous places available to employees and applicants for employment.
- (f) The Contractor shall comply with Executive Order 11246, as amended, and the rules, regulations, and orders of the Secretary of Labor.
- (g) The Contractor shall furnish all information and reports required by Executive Order 11246, as amended, Section 503 of the Rehabilitation Act of 1973, as amended, and by rules, regulations, and orders of the Secretary of Labor, or pursuant thereto. The Contractor shall permit access to its books, records, and accounts by the Secretary of Labor for purposes of investigation to ascertain compliance with such rules, regulations, and orders.
- (h) In the event of a determination that the Contractor is not in compliance with this clause or any rule, regulation, or order of the Secretary of Labor, this contract may be canceled, terminated, or suspended in whole or in part, and the Contractor may be declared ineligible for further Government contracts, or Federally assisted construction contracts under the procedures authorized in Executive Order 11246, as amended. In addition, sanctions may be imposed and remedies invoked against the Contractor as provided in Executive Order 11246, as amended, the rules, regulations, and orders of the Secretary of Labor, or as otherwise provided by law.
- (i) The Contractor shall include the terms and conditions of this clause in every subcontract or purchase order unless exempted by the rules, regulations, or orders of the Secretary of Labor issued under Executive Order 11246, as amended, so that these terms and conditions will be binding upon each subcontractor or vendor. The Contractor shall take such action with respect to any subcontract or purchase order as the Secretary of Housing and Urban Development or the Secretary of Labor may direct as a means of enforcing such provisions, including sanctions for noncompliance; provided that if the Contractor becomes involved in, or is threatened with, litigation with a subcontractor or vendor as a result of such direction, the Contractor may request the United States to enter into the litigation to protect the interests of the United States.
- (j) Compliance with the requirements of this clause shall be to the maximum extent consistent with, but not in derogation of, compliance with section 7(b) of the Indian Self-Determination and Education Assistance Act and the Indian Preference clause of this contract.
- 40. Employment, Training, and Contracting Opportunities for Low-Income Persons, Section 3 of the Housing and Urban Development Act of 1968.**
- (a) The work to be performed under this contract is subject to the requirements of section 3 of the Housing and Urban Development Act of 1968, as amended, 12 U.S.C. 1701u (section 3). The purpose of section 3 is to ensure that employment and other economic opportunities generated by HUD assistance or HUD-assisted projects covered by section 3, shall, to the greatest extent feasible, be directed to low- and very low-income persons, particularly persons who are recipients of HUD assistance for housing.
- (b) The parties to this contract agree to comply with HUD's regulations in 24 CFR Part 135, which implement section 3. As evidenced by their execution of this contract, the parties to this contract certify that they are under no contractual or other impediment that would prevent them from complying with the Part 135 regulations.
- (c) The contractor agrees to send to each labor organization or representative of workers with which the contractor has a collective bargaining agreement or other understanding, if any, a notice advising the labor organization or workers' representative of the contractor's commitments under this section 3 clause, and will post copies of the notice in conspicuous places at the work site where both employees and applicants for training and employment positions can see the notice. The notice shall describe the section 3 preference, shall set forth minimum number and job titles subject to hire, availability of apprenticeship and training positions, the qualifications for each; and the name and location of the person(s) taking applications for each of the positions; and the anticipated date the work shall begin.
- (d) The contractor agrees to include this section 3 clause in every subcontract subject to compliance with regulations in 24 CFR Part 135, and agrees to take appropriate action, as provided in an applicable provision of the subcontract or in this section 3 clause, upon a finding that the subcontractor is in violation of the regulations in 24 CFR Part 135. The contractor will not subcontract with any subcontractor where the contractor has notice or knowledge that the subcontractor has been found in violation of the regulations in 24 CFR Part 135.
- (e) The contractor will certify that any vacant employment positions, including training positions, that are filled (1) after the contractor is selected but before the contract is executed, and (2) with persons other than those to whom the regulations of 24 CFR Part 135 require employment opportunities to be directed, were not filled to circumvent the contractor's obligations under 24 CFR Part 135.
- (f) Noncompliance with HUD's regulations in 24 CFR Part 135 may result in sanctions, termination of this contract for default, and debarment or suspension from future HUD assisted contracts.
- (g) With respect to work performed in connection with section 3 covered Indian housing assistance, section 7(b) of the Indian Self-Determination and Education Assistance Act (25 U.S.C. 450e) also applies to the work to be performed under this contract. Section 7(b) requires that to the greatest extent feasible (i) preference and opportunities for training and employment shall be given to Indians, and (ii) preference in the award of contracts and subcontracts shall be given to Indian organizations and Indian-owned Economic Enterprises. Parties to this contract that are subject to the provisions of section 3 and section 7(b) agree to comply with section 3 to the maximum extent feasible, but not in derogation of compliance with section 7(b).

41. Interest of Members of Congress

No member of or delegate to the Congress of the United States of America shall be admitted to any share or part of this contract or to any benefit that may arise therefrom.

42. Interest of Members, Officers, or Employees and Former Members, Officers, or Employees

No member, officer, or employee of the PHA, no member of the governing body of the locality in which the project is situated, no member of the governing body of the locality in which the PHA was activated, and no other public official of such locality or localities who exercises any functions or responsibilities with respect to the project, shall, during his or her tenure, or for one year thereafter, have any interest, direct or indirect, in this contract or the proceeds thereof.

43. Limitations on Payments made to Influence Certain Federal Financial Transactions

- (a) The Contractor agrees to comply with Section 1352 of Title 31, United States Code which prohibits the use of Federal appropriated funds to pay any person for influencing or attempting to influence an officer or employee of any agency, a Member of Congress, and officer or employee of Congress, or an employee of a Member of Congress in connection with any of the following covered Federal actions: the awarding of any Federal contract; the making of any Federal grant; the making of any Federal loan; the entering into of any cooperative agreement; or the modification of any Federal contract, grant, loan, or cooperative agreement.
- (b) The Contractor further agrees to comply with the requirement of the Act to furnish a disclosure (OMB Standard Form LLL, Disclosure of Lobbying Activities) if any funds other than Federal appropriated funds (including profit or fee received under a covered Federal transaction) have been paid, or will be paid, to any person for influencing or attempting to influence an officer or employee of any agency, a Member of Congress, an officer or employee of Congress, or an employee of a Member of Congress in connection with a Federal contract, grant, loan, or cooperative agreement.

44. Royalties and Patents

The Contractor shall pay all royalties and license fees. It shall defend all suits or claims for infringement of any patent rights and shall save the PHA harmless from loss on account thereof; except that the PHA shall be responsible for all such loss when a particular design, process or the product of a particular manufacturer or manufacturers is specified and the Contractor has no reason to believe that the specified design, process, or product is an infringement. If, however, the Contractor has reason to believe that any design, process or product specified is an infringement of a patent, the Contractor shall promptly notify the Contracting Officer. Failure to give such notice shall make the Contractor responsible for resultant loss.

45. Examination and Retention of Contractor's Records

- (a) The PHA, HUD, or Comptroller General of the United States, or any of their duly authorized representatives shall, until 3 years after final payment under this contract, have access to and the right to examine any of the Contractor's directly pertinent books, documents, papers, or other records involving transactions related to this contract for the purpose of making audit, examination, excerpts, and transcriptions.
- (b) The Contractor agrees to include in first-tier subcontracts under this contract a clause substantially the same as paragraph (a) above. "Subcontract," as used in this clause, excludes purchase orders not exceeding \$10,000.
- (c) The periods of access and examination in paragraphs (a) and (b) above for records relating to (1) appeals under the Disputes clause of this contract, (2) litigation or settlement of claims arising from the performance of this contract, or (3) costs and expenses of this contract to which the PHA, HUD, or Comptroller General or any of their duly authorized representatives has taken exception shall continue until disposition of such appeals, litigation, claims, or exceptions.

46. Labor Standards - Davis-Bacon and Related Acts

If the total amount of this contract exceeds \$2,000, the Federal labor standards set forth in the clause below shall apply to the development or construction work to be performed under the contract.

- (a) Minimum Wages.
 - (1) All laborers and mechanics employed under this contract in the development or construction of the project(s) involved will be paid unconditionally and not less often than once a week, and without subsequent deduction or rebate on any account (except such payroll deductions as are permitted by regulations issued by the Secretary of Labor under the Copeland Act (29 CFR Part 3)), the full amount of wages and bona fide fringe benefits (or cash equivalents thereof) due at time of payment computed at rates not less than those contained in the wage determination of the Secretary of Labor which is attached hereto and made a part hereof, regardless of any contractual relationship which may be alleged to exist between the Contractor and such laborers and mechanics. Contributions made or costs reasonably anticipated for bona fide fringe benefits under Section 1(b)(2) of the Davis-Bacon Act on behalf of laborers or mechanics are considered wages paid to such laborers or mechanics, subject to the provisions of 29 CFR 5.5(a)(1)(iv); also, regular contributions made or costs incurred for more than a weekly period (but not less often than quarterly) under plans, funds, or programs which cover the regular weekly period, are deemed to be constructively made or incurred during such weekly period. Such laborers and mechanics shall be paid the appropriate wage rate and fringe benefits in the wage determination for the classification of work actually performed, without regard to skill, except as provided in 29 CFR 5.5(a)(4). Laborers or mechanics performing work in more than one classification may be compensated at the rate specified for each classification for the time actually worked therein; provided, that the employer's payroll records accurately set forth the time spent in each classification in which work is performed. The wage determination (including any additional classification and wage rates conformed under 29 CFR 5.5(a)(1)(ii) and the Davis-Bacon poster (WH-1321) shall

be posted at all times by the Contractor and its subcontractors at the site of the work in a prominent and accessible place where it can be easily seen by the workers.

- (2) (i) Any class of laborers or mechanics, including helpers, which is not listed in the wage determination and which is to be employed under the contract shall be classified in conformance with the wage determination. HUD shall approve an additional classification and wage rate and fringe benefits therefor only when all the following criteria have been met: (A) The work to be performed by the classification requested is not performed by a classification in the wage determination; and (B) The classification is utilized in the area by the construction industry; and (C) The proposed wage rate, including any bona fide fringe benefits, bears a reasonable relationship to the wage rates contained in the wage determination.
- (ii) If the Contractor and the laborers and mechanics to be employed in the classification (if known), or their representatives, and HUD or its designee agree on the classification and wage rate (including the amount designated for fringe benefits where appropriate), a report of the action taken shall be sent by HUD or its designee to the Administrator of the Wage and Hour Division, Employee Standards Administration, U.S. Department of Labor, Washington, DC 20210. The Administrator, or an authorized representative, will approve, modify, or disapprove every additional classification action within 30 days of receipt and so advise HUD or its designee or will notify HUD or its designee within the 30-day period that additional time is necessary.
- (iii) In the event the Contractor, the laborers or mechanics to be employed in the classification or their representatives, and HUD or its designee do not agree on the proposed classification and wage rate (including the amount designated for fringe benefits, where appropriate), HUD or its designee shall refer the questions, including the views of all interested parties and the recommendation of HUD or its designee, to the Administrator of the Wage and Hour Division for determination. The Administrator, or an authorized representative, will issue a determination within 30 days of receipt and so advise HUD or its designee or will notify HUD or its designee within the 30-day period that additional time is necessary.
- (iv) The wage rate (including fringe benefits where appropriate) determined pursuant to subparagraphs (a)(2)(ii) or (iii) of this clause shall be paid to all workers performing work in the classification under this contract from the first day on which work is performed in classification.
- (3) Whenever the minimum wage rate prescribed in the contract for a class of laborers or mechanics includes a fringe benefit which is not expressed as an hourly rate, the Contractor shall either pay the benefit as stated in the wage determination or shall pay another bona fide fringe benefit or an hourly cash equivalent thereof.
- (4) If the Contractor does not make payments to a trustee or other third person, the Contractor may consider as part of the wages of any laborer or mechanic the

amount of any costs reasonably anticipated in providing bona fide fringe benefits under a plan or program; provided, that the Secretary of Labor has found, upon the written request of the Contractor, that the applicable standards of the Davis-Bacon Act have been met. The Secretary of Labor may require the Contractor to set aside in a separate account assets for the meeting of obligations under the plan or program.

- (b) Withholding of funds. HUD or its designee shall, upon its own action or upon written request of an authorized representative of the Department of Labor, withhold or cause to be withheld from the Contractor under this contract or any other Federal contract with the same prime Contractor, or any other Federally-assisted contract subject to Davis-Bacon prevailing wage requirements, which is held by the same prime Contractor, so much of the accrued payments or advances as may be considered necessary to pay laborers and mechanics, including apprentices, trainees, and helpers, employed by the Contractor or any subcontractor the full amount of wages required by the contract. In the event of failure to pay any laborer or mechanic, including any apprentice, trainee, or helper, employed or working in the construction or development of the project, all or part of the wages required by the contract, HUD or its designee may, after written notice to the Contractor, take such action as may be necessary to cause the suspension of any further payment, advance, or guarantee of funds until such violations have ceased. HUD or its designee may, after written notice to the Contractor, disburse such amounts withheld for and on account of the Contractor or subcontractor to the respective employees to whom they are due.
- (c) Payrolls and basic records.
- (1) Payrolls and basic records relating thereto shall be maintained by the Contractor during the course of the work and preserved for a period of three years thereafter for all laborers and mechanics working in the construction or development of the project. Such records shall contain the name, address, and social security number of each such worker, his or her correct classification, hourly rates of wages paid (including rates of contributions or costs anticipated for bona fide fringe benefits or cash equivalents thereof of the types described in section 1(b)(2)(B) of the Davis-Bacon Act), daily and weekly number of hours worked, deductions made, and actual wages paid. Whenever the Secretary of Labor has found, under 29 CFR 5.5(a)(1)(iv), that the wages of any laborer or mechanic include the amount of costs reasonably anticipated in providing benefits under a plan or program described in section 1(b)(2)(B) of the Davis-Bacon Act, the Contractor shall maintain records which show that the commitment to provide such benefits is enforceable, that the plan or program is financially responsible, and that the plan or program has been communicated in writing to the laborers or mechanics affected, and records which show the costs anticipated or the actual cost incurred in providing such benefits. Contractors employing apprentices or trainees under approved programs shall maintain written evidence of the registration of apprenticeship programs and certification of trainee programs, the registration of the apprentices and trainees, and the ratios and wage rates prescribed in the applicable programs.

- (2) (i) The Contractor shall submit weekly for each week in which any contract work is performed a copy of all payrolls to the Contracting Officer for transmission to HUD or its designee. The payrolls submitted shall set out accurately and completely all of the information required to be maintained under subparagraph (c)(1) of this clause. This information may be submitted in any form desired. Optional Form WH-347 (Federal Stock Number 029-005-00014-1) is available for this purpose and may be purchased from the Superintendent of Documents, U.S. Government Printing Office, Washington, D.C. 20402. The Contractor is responsible for the submission of copies of payrolls by all subcontractors. (Approved by the Office of Management and Budget under OMB Control Number 1214-0149.)
- (ii) Each payroll submitted shall be accompanied by a "Statement of Compliance," signed by the Contractor or subcontractor or his or her agent who pays or supervises the payment of the persons employed under the contract and shall certify the following:
- (A) That the payroll for the payroll period contains the information required to be maintained under paragraph (c) (1) of this clause and that such information is correct and complete;
- (B) That each laborer or mechanic (including each helper, apprentice, and trainee) employed on the contract during the payroll period has been paid the full weekly wages earned, without rebate, either directly or indirectly, and that no deductions have been made either directly or indirectly from the full wages earned, other than permissible deductions as set forth in 29 CFR Part 3; and
- (C) That each laborer or mechanic has been paid not less than the applicable wage rates and fringe benefits or cash equivalents for the classification of work performed, as specified in the applicable wage determination incorporated into the contract.
- (iii) The weekly submission of a properly executed certification set forth on the reverse side of Optional Form WH-347 shall satisfy the requirements for submission of the "Statement of Compliance" required by subparagraph (c)(2)(ii) of this clause.
- (iv) The falsification of any of the above certifications may subject the Contractor or subcontractor to civil or criminal prosecution under Section 1001 of Title 18 and Section 3729 of Title 31 of the United States Code.
- (3) The Contractor or subcontractor shall make the records required under subparagraph (c)(1) available for inspection, copying, or transcription by authorized representatives of HUD or its designee, the Contracting Officer, or the Department of Labor and shall permit such representatives to interview employees during working hours on the job. If the Contractor or subcontractor fails to submit the required records or to make them available, HUD or its designee may, after written notice to the Contractor, take such action as may be necessary to cause the suspension of any further payment, advance, or guarantee of funds. Furthermore, failure to submit the required records upon request or to

make such records available may be grounds for debarment action pursuant to 29 CFR 5.12.

- (d) (1) Apprentices. Apprentices will be permitted to work at less than the predetermined rate for the work they performed when they are employed pursuant to and individually registered in a bona fide apprenticeship program registered with the U.S. Department of Labor, Employment and Training Administration, Office of Apprenticeship and Training, Employer and Labor Services (OATELS), or with a State Apprenticeship Agency recognized by OATELS, or if a person is employed in his or her first 90 days of probationary employment as an apprentice in such an apprenticeship program, who is not individually registered in the program, but who has been certified by OATELS or a State Apprenticeship Agency (where appropriate) to be eligible for probationary employment as an apprentice. The allowable ratio of apprentices to journeymen on the job site in any craft classification shall not be greater than the ratio permitted to the Contractor as to the entire work force under the registered program. Any worker listed on a payroll at an apprentice wage rate, who is not registered or otherwise employed as stated in this paragraph, shall be paid not less than the applicable wage rate on the wage determination for the classification of work actually performed. In addition, any apprentice performing work on the job site in excess of the ratio permitted under the registered program shall be paid not less than the applicable wage rate on the wage determination for the work actually performed. Where a contractor is performing construction on a project in a locality other than that in which its program is registered, the ratios and wage rates (expressed in percentages of the journeyman's hourly rate) specified in the Contractor's or subcontractor's registered program shall be observed. Every apprentice must be paid at not less than the rate specified in the registered program for the apprentice's level of progress, expressed as a percentage of the journeyman hourly rate specified in the applicable wage determination. Apprentices shall be paid fringe benefits in accordance with the provisions of the apprenticeship program. If the apprenticeship program does not specify fringe benefits, apprentices must be paid the full amount of fringe benefits listed on the wage determination for the applicable classification. If the Administrator of the Wage and Hour Division determines that a different practice prevails for the applicable apprentice classification, fringes shall be paid in accordance with that determination. In the event OATELS, or a State Apprenticeship Agency recognized by OATELS, withdraws approval of an apprenticeship program, the Contractor will no longer be permitted to utilize apprentices at less than the applicable predetermined rate for the work performed until an acceptable program is approved.
- (2) Trainees. Except as provided in 29 CFR 5.16, trainees will not be permitted to work at less than the predetermined rate for the work performed unless they are employed pursuant to and individually registered in a program which has received prior approval, evidenced by formal certification by the U.S. Department of Labor, Employment and Training Administration. The ratio of trainees to journeymen on the job site shall not be greater than permitted under

the plan approved by the Employment and Training Administration. Every trainee must be paid at not less than the rate specified in the approved program for the trainee's level of progress, expressed as a percentage of the journeyman hourly rate specified in the applicable wage determination. Trainees shall be paid fringe benefits in accordance with the provisions of the trainee program. If the trainee program does not mention fringe benefits, trainees shall be paid the full amount of fringe benefits listed in the wage determination unless the Administrator of the Wage and Hour Division determines that there is an apprenticeship program associated with the corresponding journeyman wage rate in the wage determination which provides for less than full fringe benefits for apprentices. Any employee listed on the payroll at a trainee rate who is not registered and participating in a training plan approved by the Employment and Training Administration shall be paid not less than the applicable wage rate in the wage determination for the classification of work actually performed. In addition, any trainee performing work on the job site in excess of the ratio permitted under the registered program shall be paid not less than the applicable wage rate in the wage determination for the work actually performed. In the event the Employment and Training Administration withdraws approval of a training program, the Contractor will no longer be permitted to utilize trainees at less than the applicable predetermined rate for the work performed until an acceptable program is approved.

- (3) Equal employment opportunity. The utilization of apprentices, trainees, and journeymen under this clause shall be in conformity with the equal employment opportunity requirements of Executive Order 11246, as amended, and 29 CFR Part 30.
- (e) Compliance with Copeland Act requirements. The Contractor shall comply with the requirements of 29 CFR Part 3, which are hereby incorporated by reference in this contract.
- (f) Contract termination; debarment. A breach of this contract clause may be grounds for termination of the contract and for debarment as a Contractor and a subcontractor as provided in 29 CFR 5.12.
- (g) Compliance with Davis-Bacon and related Act requirements. All rulings and interpretations of the Davis-Bacon and related Acts contained in 29 CFR Parts 1, 3, and 5 are herein incorporated by reference in this contract.
- (h) Disputes concerning labor standards. Disputes arising out of the labor standards provisions of this clause shall not be subject to the general disputes clause of this contract. Such disputes shall be resolved in accordance with the procedures of the Department of Labor set forth in 29 CFR Parts 5, 6, and 7. Disputes within the meaning of this clause include disputes between the Contractor (or any of its subcontractors) and the PHA, HUD, the U.S. Department of Labor, or the employees or their representatives.
- (i) Certification of eligibility.
 - (1) By entering into this contract, the Contractor certifies that neither it (nor he or she) nor any person or firm who has an interest in the Contractor's firm is a person or firm ineligible to be awarded contracts by the United States Government by virtue of section 3(a) of the Davis-Bacon Act or 29 CFR 5.12(a)(1).

- (2) No part of this contract shall be subcontracted to any person or firm ineligible for award of a United States Government contract by virtue of section 3(a) of the Davis-Bacon Act or 29 CFR 5.12(a)(1).
 - (3) The penalty for making false statements is prescribed in the U. S. Criminal Code, 18 U.S.C. 1001.
- (j) Contract Work Hours and Safety Standards Act. As used in this paragraph, the terms "laborers" and "mechanics" include watchmen and guards.
- (1) Overtime requirements. No contractor or subcontractor contracting for any part of the contract work which may require or involve the employment of laborers or mechanics, including watchmen and guards, shall require or permit any such laborer or mechanic in any workweek in which the individual is employed on such work to work in excess of 40 hours in such workweek unless such laborer or mechanic receives compensation at a rate not less than one and one-half times the basic rate of pay for all hours worked in excess of 40 hours in such workweek.
 - (2) Violation; liability for unpaid wages; liquidated damages. In the event of any violation of the provisions set forth in subparagraph (j)(1) of this clause, the Contractor and any subcontractor responsible therefor shall be liable for the unpaid wages. In addition, such Contractor and subcontractor shall be liable to the United States (in the case of work done under contract for the District of Columbia or a territory, to such District or to such territory), for liquidated damages. Such liquidated damages shall be computed with respect to each individual laborer or mechanic (including watchmen and guards) employed in violation of the provisions set forth in subparagraph (j)(1) of this clause, in the sum of \$10 for each calendar day on which such individual was required or permitted to work in excess of the standard workweek of 40 hours without payment of the overtime wages required by provisions set forth in subparagraph (j)(1) of this clause.
 - (3) Withholding for unpaid wages and liquidated damages. HUD or its designee shall upon its own action or upon written request of an authorized representative of the Department of Labor withhold or cause to be withheld, from any moneys payable on account of work performed by the Contractor or subcontractor under any such contract or any Federal contract with the same prime Contractor, or any other Federally-assisted contract subject to the Contract Work Hours and Safety Standards Act, which is held by the same prime Contractor, such sums as may be determined to be necessary to satisfy any liabilities of such Contractor or subcontractor for unpaid wages and liquidated damages as provided in the provisions set forth in subparagraph (j)(2) of this clause.
- (k) Subcontracts. The Contractor or subcontractor shall insert in any subcontracts all the provisions contained in this clause, and such other clauses as HUD or its designee may by appropriate instructions require, and also a clause requiring the subcontractors to include these provisions in any lower tier subcontracts. The prime Contractor shall be responsible for the compliance by any subcontractor or lower tier subcontractor with all these provisions.

47. Non-Federal Prevailing Wage Rates

- (a) Any prevailing wage rate (including basic hourly rate and any fringe benefits), determined under State or tribal law to be prevailing, with respect to any employee in any trade or position employed under the contract, is inapplicable to the contract and shall not be enforced against the Contractor or any subcontractor, with respect to employees engaged under the contract whenever such non-Federal prevailing wage rate exceeds:
 - (1) The applicable wage rate determined by the Secretary of Labor pursuant to the Davis-Bacon Act (40 U.S.C. 3141 et seq.) to be prevailing in the locality with respect to such trade;
- (b) An applicable apprentice wage rate based thereon specified in an apprenticeship program registered with the U.S. Department of Labor (DOL) or a DOL-recognized State Apprenticeship Agency; or
- (c) An applicable trainee wage rate based thereon specified in a DOL-certified trainee program.

48. Procurement of Recovered Materials.

- (a) In accordance with Section 6002 of the Solid Waste Disposal Act, as amended by the Resource Conservation and Recovery Act, the Contractor shall procure items designated in guidelines of the Environmental Protection Agency (EPA) at 40 CFR Part 247 that contain the highest percentage of recovered materials practicable, consistent with maintaining a satisfactory level of competition. The Contractor shall procure items designated in the EPA guidelines that contain the highest percentage of recovered materials practicable unless the Contractor determines that such items: (1) are not reasonably available in a reasonable period of time; (2) fail to meet reasonable performance standards, which shall be determined on the basis of the guidelines of the National Institute of Standards and Technology, if applicable to the item; or (3) are only available at an unreasonable price.
- (b) Paragraph (a) of this clause shall apply to items purchased under this contract where: (1) the Contractor purchases in excess of \$10,000 of the item under this contract; or (2) during the preceding Federal fiscal year, the Contractor: (i) purchased any amount of the items for use under a contract that was funded with Federal appropriations and was with a Federal agency or a State agency or agency of a political subdivision of a State; and (ii) purchased a total of in excess of \$10,000 of the item both under and outside that contract.

COMPETENCE OF WORKMEN

Every worker on any part of this Contract shall be competent to perform the task to which he/she is assigned. Supervision for each crew shall be done by a Foreman or Superintendent that is capable of directing the work. Conditions which require the constant presence of a Housing Authority of the City of Tampa Inspector to assure the quality of the work will not be tolerated. Any worker who does not produce quality workmanship through lack of cooperation or incompetence shall be promptly removed from the job upon written order by the Authority. The judge of quality of workmanship shall be the Housing Authority of the City of Tampa.

AFFIRMATIVE ACTION REQUIREMENT

Under Executive Order 11246, as amended, the Housing Authority shall advise all construction-related Contractors and contracts over \$10,000 to document affirmative actions taken to ensure equal opportunity in employment. This documentation is subject to review by the Regional Office of the Department of Labor. As a part of normal contract administration, the Housing Authority will determine compliance with the equal opportunity clause or written affirmative action requirements and will review Contractor performance to ensure that these responsibilities are met.

RESPONSIBILITIES OF CONTRACTORS AND SUBCONTRACTORS

All Contractors and Subcontractors on modernization activities are required to take affirmative action to comply with the equal employment opportunity provisions of Executive Order 11246, as amended.

CONTRACT PERIOD

The Contractor shall complete all work required under this contract within **180** calendar days of the effective date of the

contract or within the time schedule established in the notice to proceed issued by the Contracting Officer.

The Contractor shall make all specified areas of work available for the Owner's use on the effective date of the Certificate of Substantial Completion. The Contractor will complete and/or correct all of the Work on the Punch List items developed by Owner and/or the Architect within **20** days from the completion date or liquidated damages shall apply.

LIQUIDATED DAMAGES

If the Contractor fails to complete the work within the time specified in the contract, or any extension, as specified in the clause entitled Default of this contract, the Contractor shall pay to THA as liquidated damages, the sum of **\$500** for each day of delay. If different completion dates are specified in the contract for separate parts or stages of the work, the amount of liquidated damages shall be assessed on those parts or stages which are delayed. To the extent that the Contractor's delay or nonperformance is excused under another clause in this contract, liquidated damages shall not be due to THA. The Contractor remains liable for damages caused other than by delay.

MINORITY BUSINESS ENTERPRISE OPPORTUNITY**MBE REQUIREMENTS**

Under Executive Orders 11625 and 12432, the Housing Authority, as part of its Affirmative Action Program, provides every feasible opportunity for minority and women business enterprises to participate in bidding for work. In accordance with the Department of HUD regulation, the Authority is required to establish a goal of awarding at least 20 percent (20%) of the dollar value of construction contracts to Minority Business Enterprises or General Contractors with 20% MBE participation. The contractor shall make regular reports as required by the

General Decision Number: FL190116 01/04/2019 FL116

Superseded General Decision Number: FL20180159

State: Florida

Construction Type: Heavy

County: Hillsborough County in Florida.

HEAVY CONSTRUCTION PROJECTS (Including Sewer and Water Lines)

Note: Under Executive Order (EO) 13658, an hourly minimum wage of \$10.60 for calendar year 2019 applies to all contracts subject to the Davis-Bacon Act for which the contract is awarded (and any solicitation was issued) on or after January 1, 2015. If this contract is covered by the EO, the contractor must pay all workers in any classification listed on this wage determination at least \$10.60 per hour (or the applicable wage rate listed on this wage determination, if it is higher) for all hours spent performing on the contract in calendar year 2019. If this contract is covered by the EO and a classification considered necessary for performance of work on the contract does not appear on this wage determination, the contractor must pay workers in that classification at least the wage rate determined through the conformance process set forth in 29 CFR 5.5(a)(1)(ii) (or the EO minimum wage rate, if it is higher than the conformed wage rate). The EO minimum wage rate will be adjusted annually. Please note that this EO applies to the above-mentioned types of contracts entered into by the federal government that are subject to the Davis-Bacon Act itself, but it does not apply to contracts subject only to the Davis-Bacon Related Acts, including those set forth at 29 CFR 5.1(a)(2)-(60). Additional information on contractor requirements and worker protections under the EO is available at www.dol.gov/whd/govcontracts.

Modification Number	Publication Date
0	01/04/2019

ELEC0915-003 12/01/2017

	Rates	Fringes
ELECTRICIAN.....	\$ 28.18	38%+0.35

ENGI0925-010 06/01/2013

	Rates	Fringes
POWER EQUIPMENT OPERATOR: Crawler Cranes; Truck Cranes; Pile Driver Cranes; Rough Terrain Cranes; and Any Crane not otherwise described below...	\$ 29.61	11.50

Drill.....	\$ 29.61	11.50
Hydraulic Cranes Rated 100 Tons or Above but Less Than 250 Tons; and Lattice Boom Cranes Less Than 150 Tons if not described below.	\$ 30.61	11.50
Lattice Boom Cranes Rated at 150 Tons or Above; Friction Cranes of Any Size; Mobile Tower Cranes or Luffing Boom Cranes of Any Size; Electric Tower Cranes; Hydraulic Cranes Rated at 250 Tons or Above; and Any Crane Equipped with 300 Foot or More of Any Boom Combination.....	\$ 31.61	11.50
Oiler.....	\$ 22.91	11.50

* IRON0397-006 07/01/2018		
	Rates	Fringes
IRONWORKER, STRUCTURAL.....	\$ 29.85	15.97

LABO0517-002 05/01/2017		
	Rates	Fringes
LABORER: Grade Checker.....	\$ 19.20	7.85

PAIN0088-008 08/01/2018		
	Rates	Fringes
PAINTER: Brush, Roller and Spray.....	\$ 20.21	10.73

SUFL2009-155 06/24/2009		
	Rates	Fringes
CARPENTER.....	\$ 14.95	2.92
CEMENT MASON/CONCRETE FINISHER...	\$ 14.77	3.50
LABORER: Common or General.....	\$ 10.06	0.00
LABORER: Landscape.....	\$ 7.25	0.00
LABORER: Pipelayer.....	\$ 11.33	0.00
LABORER: Power Tool Operator (Hand Held Drills/Saws, Jackhammer and Power Saws Only).....	\$ 10.63	2.20
OPERATOR: Asphalt Paver.....	\$ 11.59	0.00

OPERATOR: Backhoe Loader Combo.....	\$ 16.10	2.44
OPERATOR: Backhoe/Excavator.....	\$ 16.00	0.00
OPERATOR: Bulldozer.....	\$ 17.00	0.00
OPERATOR: Grader/Blade.....	\$ 16.00	2.84
OPERATOR: Loader.....	\$ 17.00	0.00
OPERATOR: Mechanic.....	\$ 14.32	0.00
OPERATOR: Roller.....	\$ 10.76	0.00
OPERATOR: Scraper.....	\$ 11.00	1.74
OPERATOR: Trackhoe.....	\$ 20.92	5.50
OPERATOR: Tractor.....	\$ 10.54	0.00
TRUCK DRIVER, Includes Dump Truck.....	\$ 11.00	0.00
TRUCK DRIVER: Lowboy Truck.....	\$ 12.73	0.00
TRUCK DRIVER: Off the Road Truck.....	\$ 12.21	1.97

WELDERS - Receive rate prescribed for craft performing operation to which welding is incidental.

=====

Note: Executive Order (EO) 13706, Establishing Paid Sick Leave for Federal Contractors applies to all contracts subject to the Davis-Bacon Act for which the contract is awarded (and any solicitation was issued) on or after January 1, 2017. If this contract is covered by the EO, the contractor must provide employees with 1 hour of paid sick leave for every 30 hours they work, up to 56 hours of paid sick leave each year. Employees must be permitted to use paid sick leave for their own illness, injury or other health-related needs, including preventive care; to assist a family member (or person who is like family to the employee) who is ill, injured, or has other health-related needs, including preventive care; or for reasons resulting from, or to assist a family member (or person who is like family to the employee) who is a victim of, domestic violence, sexual assault, or stalking. Additional information on contractor requirements and worker protections under the EO is available at www.dol.gov/whd/govcontracts.

Unlisted classifications needed for work not included within the scope of the classifications listed may be added after award only as provided in the labor standards contract clauses (29CFR 5.5 (a) (1) (ii)).

The body of each wage determination lists the classification and wage rates that have been found to be prevailing for the cited type(s) of construction in the area covered by the wage determination. The classifications are listed in alphabetical order of "identifiers" that indicate whether the particular rate is a union rate (current union negotiated rate for local), a survey rate (weighted average rate) or a union average rate (weighted union average rate).

Union Rate Identifiers

A four letter classification abbreviation identifier enclosed in dotted lines beginning with characters other than "SU" or "UAVG" denotes that the union classification and rate were prevailing for that classification in the survey. Example: PLUM0198-005 07/01/2014. PLUM is an abbreviation identifier of the union which prevailed in the survey for this classification, which in this example would be Plumbers. 0198 indicates the local union number or district council number where applicable, i.e., Plumbers Local 0198. The next number, 005 in the example, is an internal number used in processing the wage determination. 07/01/2014 is the effective date of the most current negotiated rate, which in this example is July 1, 2014.

Union prevailing wage rates are updated to reflect all rate changes in the collective bargaining agreement (CBA) governing this classification and rate.

Survey Rate Identifiers

Classifications listed under the "SU" identifier indicate that no one rate prevailed for this classification in the survey and the published rate is derived by computing a weighted average rate based on all the rates reported in the survey for that classification. As this weighted average rate includes all rates reported in the survey, it may include both union and non-union rates. Example: SULA2012-007 5/13/2014. SU indicates the rates are survey rates based on a weighted average calculation of rates and are not majority rates. LA indicates the State of Louisiana. 2012 is the year of survey on which these classifications and rates are based. The next number, 007 in the example, is an internal number used in producing the wage determination. 5/13/2014 indicates the survey completion date for the classifications and rates under that identifier.

Survey wage rates are not updated and remain in effect until a new survey is conducted.

Union Average Rate Identifiers

Classification(s) listed under the UAVG identifier indicate that no single majority rate prevailed for those classifications; however, 100% of the data reported for the classifications was union data. EXAMPLE: UAVG-OH-0010 08/29/2014. UAVG indicates that the rate is a weighted union average rate. OH indicates the state. The next number, 0010 in the example, is an internal number used in producing the wage

determination. 08/29/2014 indicates the survey completion date for the classifications and rates under that identifier.

A UAVG rate will be updated once a year, usually in January of each year, to reflect a weighted average of the current negotiated/CBA rate of the union locals from which the rate is based.

WAGE DETERMINATION APPEALS PROCESS

1.) Has there been an initial decision in the matter? This can be:

- * an existing published wage determination
- * a survey underlying a wage determination
- * a Wage and Hour Division letter setting forth a position on a wage determination matter
- * a conformance (additional classification and rate) ruling

On survey related matters, initial contact, including requests for summaries of surveys, should be with the Wage and Hour Regional Office for the area in which the survey was conducted because those Regional Offices have responsibility for the Davis-Bacon survey program. If the response from this initial contact is not satisfactory, then the process described in 2.) and 3.) should be followed.

With regard to any other matter not yet ripe for the formal process described here, initial contact should be with the Branch of Construction Wage Determinations. Write to:

Branch of Construction Wage Determinations
Wage and Hour Division
U.S. Department of Labor
200 Constitution Avenue, N.W.
Washington, DC 20210

2.) If the answer to the question in 1.) is yes, then an interested party (those affected by the action) can request review and reconsideration from the Wage and Hour Administrator (See 29 CFR Part 1.8 and 29 CFR Part 7). Write to:

Wage and Hour Administrator
U.S. Department of Labor
200 Constitution Avenue, N.W.
Washington, DC 20210

The request should be accompanied by a full statement of the interested party's position and by any information (wage payment data, project description, area practice material, etc.) that the requestor considers relevant to the issue.

3.) If the decision of the Administrator is not favorable, an interested party may appeal directly to the Administrative Review Board (formerly the Wage Appeals Board). Write to:

Administrative Review Board
U.S. Department of Labor
200 Constitution Avenue, N.W.
Washington, DC 20210

4.) All decisions by the Administrative Review Board are final.

=====

END OF GENERAL DECISION